

Repair Manual

37 Series & 57 Series

37



57

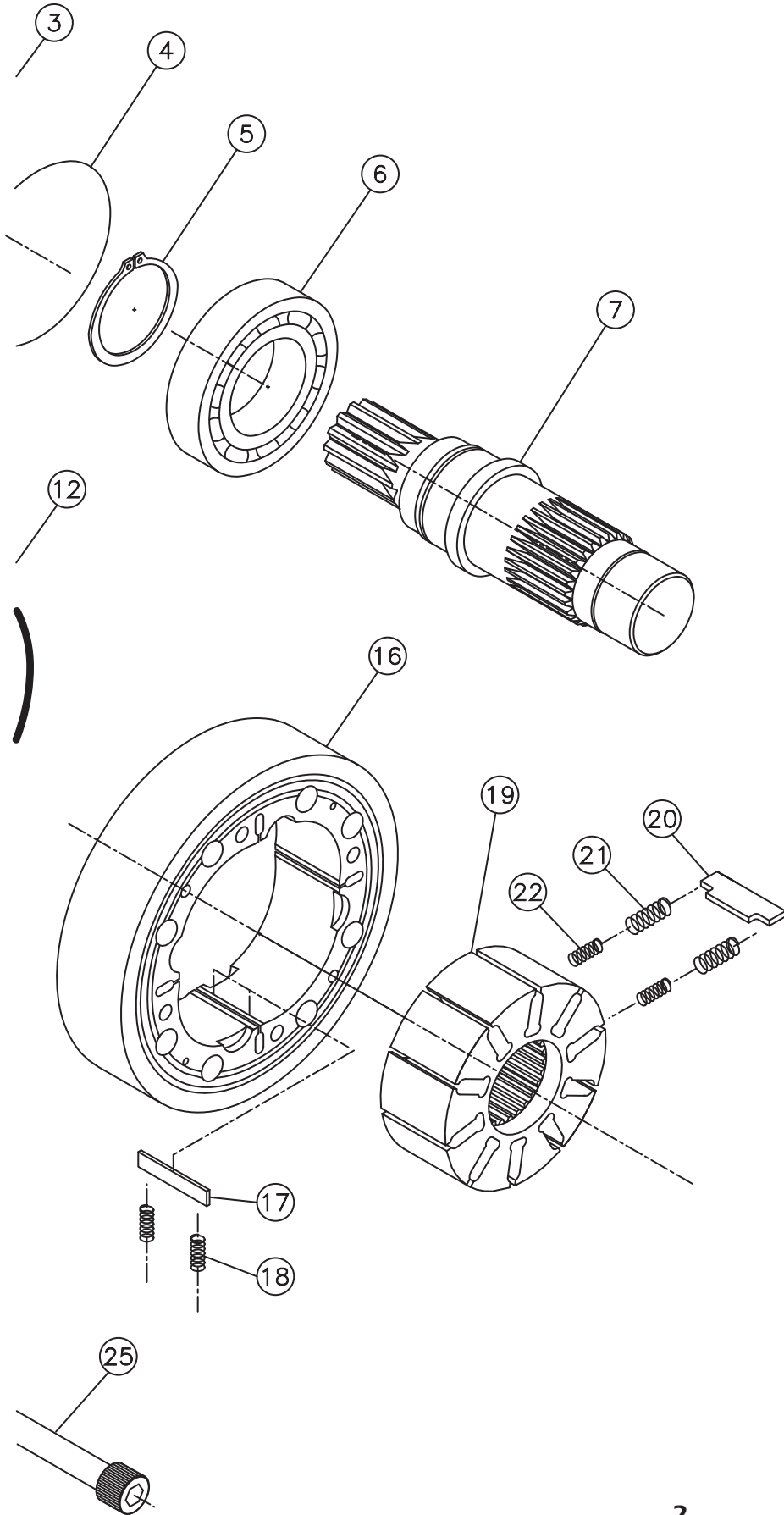

SERIES 37 EXP. VIEW, STD. "A" STYLE			
ITEM	PART NO.	DESCRIPTION	QTY
1	0370111	SEAL PLATE SNAP RING	1
2	0370152	SEAL PLATE	1
3	0370175	SEAL, SHAFT, TCN	1
4	0370114	O-RING, SEAL PLATE	1
5	0370730	SNAP RING, BEARING	1
6	0370711	BALL BEARING	1
7	0370702	SHAFT, SPLINED	1
	0370701	SHAFT, KEYED	1
8	0371123	FRONT HOUSING, A, PC	1
9	0370811	O-RING, THERMAL, INNER	2
10	0371829	O-RING, THERMAL, MIDDLE	2
11	0370810	O-RING, THERMAL, OUTER	2
12	0370610	O-RING, MAIN	4
13	0150620	PLATE SCREW	4
14	0370618	PLATE, TIMING, PC	2
15	0370431	DOWEL PIN	4
16	0370400	STATOR, GA 37	1
	0370401	STATOR, GA 32	1
	0370402	STATOR, GA 26	1
	0370403	STATOR, GA 20	1
	0370404	STATOR, GA 16	1
	0370406	STATOR, GA 12	1
17	0150410	STATOR VANE	4
18	0370420	STATOR VANE SPRING	8
19	0370300PC	ROTOR	1
	0370300PL	ROTOR	1
20	0370313PC	ROTOR VANE, S	10
	0370316PL	ROTOR VANE, L	10
21	1250320	ROTOR VANE SPRING, OUTER	20
22	1250321	ROTOR VANE SPRING, INNER	20
23	0370720	NEEDLE BEARING	1
24	0370883	REAR HOUSING, A, PC	1
25	0370901	BOLT	8

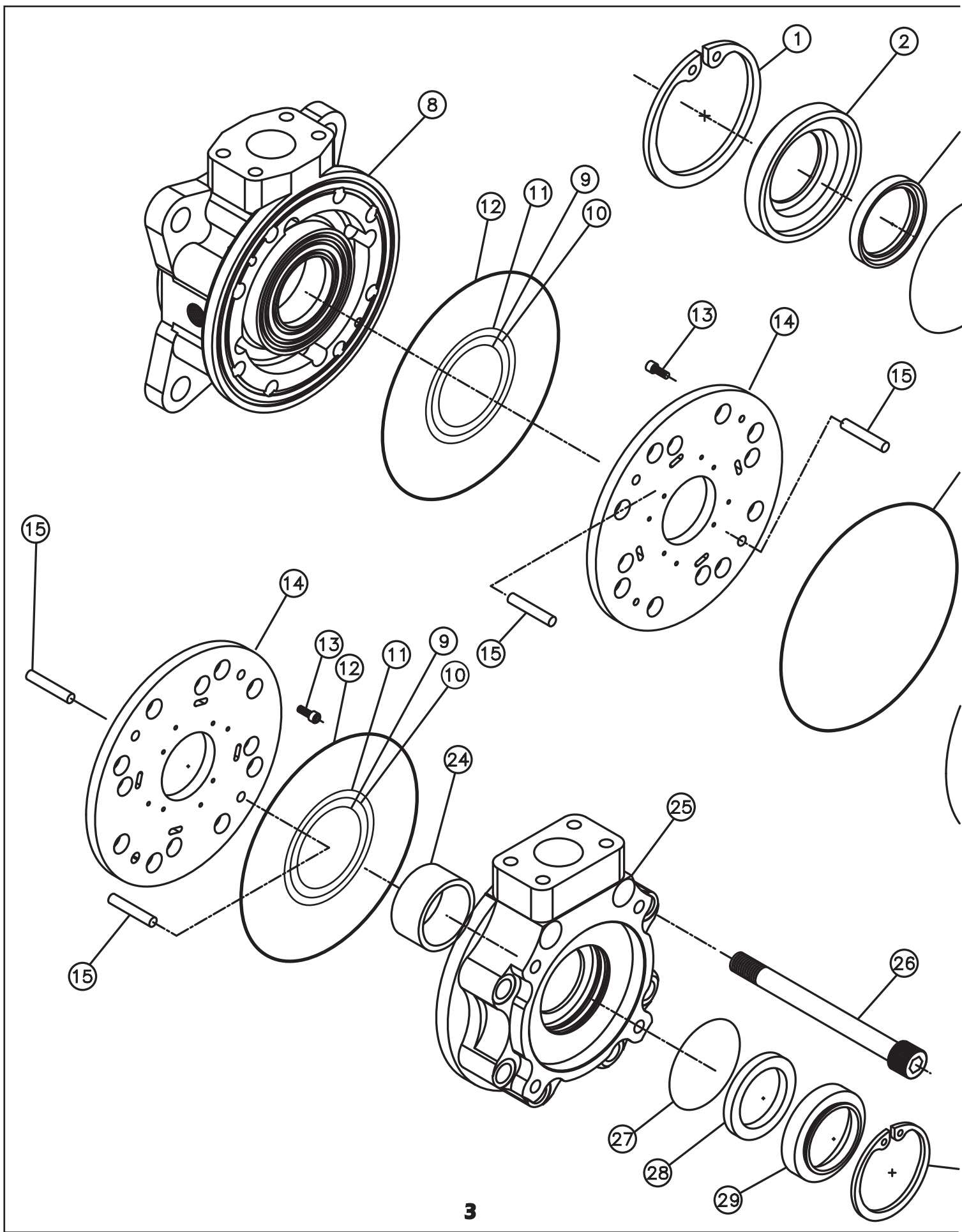

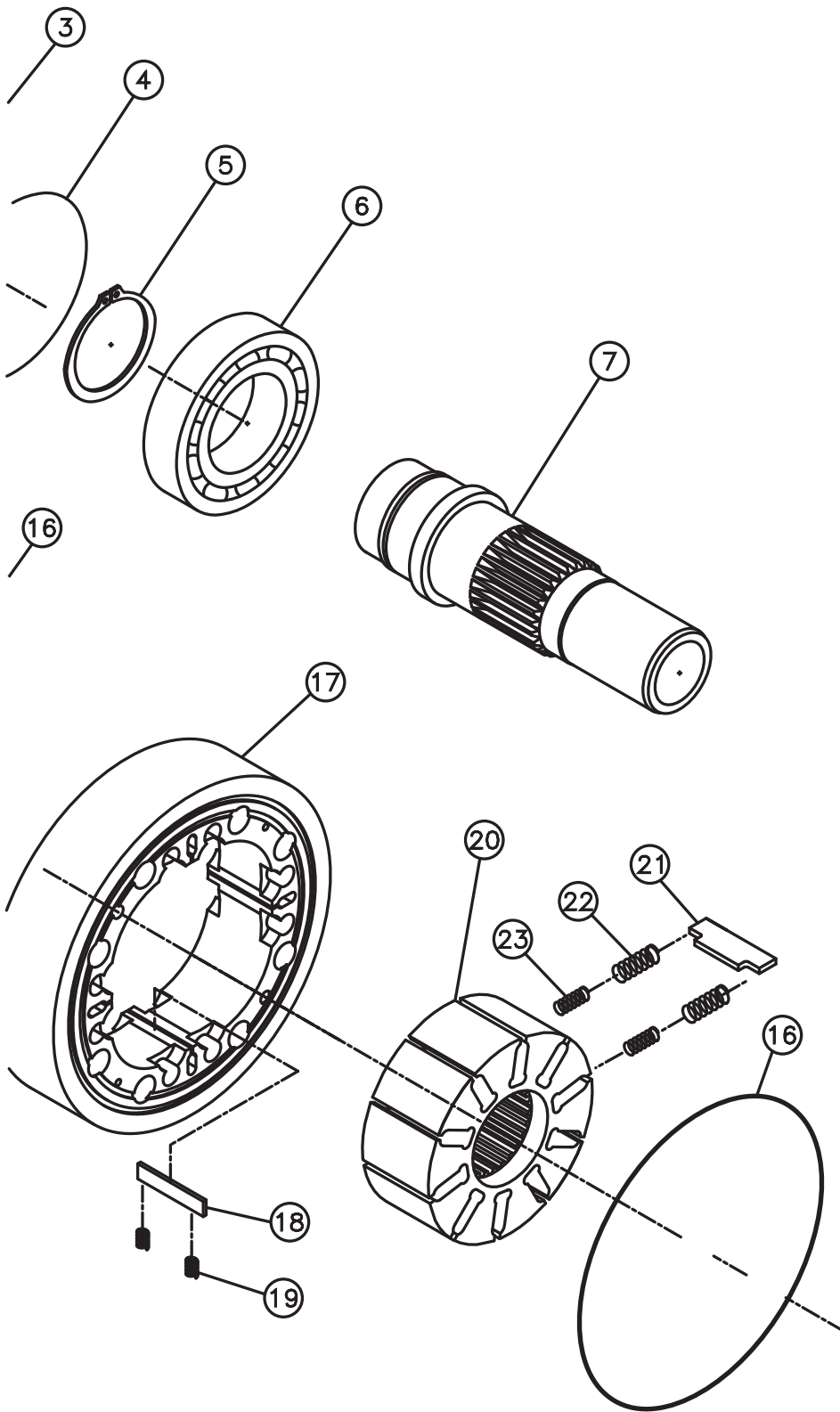

SERIES 37 EXP. VIEW, THRU KEY, "A", PC

ITEM	PART NO.	DESCRIPTION	QTY
1	0370111	SEAL PLATE SNAP RING	1
2	0370152	SEAL PLATE	1
3	0370175	SEAL, SHAFT, TCN	1
4	0370114	O-RING, SEAL PLATE	1
5	0370730	SNAP RING, BEARING	1
6	0370711	BALL BEARING	1
7	0370759	SHAFT, THRU KEY, 1-1/2	1
8	0371123	FRONT HOUSING, A, PC	1
9	0370811	O-RING, THERMAL SMALL	2
10	0371829	O-RING, THERMAL MIDDLE	2
11	0370810	O-RING, THERMAL LARGE	2
12	0370610	O-RING, MAIN	2
13	0150620	PLATE SCREW	4
14	0370618	PLATE, PC	2
15	0370431	DOWEL PIN	4
16	0370610	O-RING, MAIN	2
17	0370400	STATOR, GA 37	1
	0370401	STATOR, GA 32	1
	0370402	STATOR, GA 26	1
	0370403	STATOR, GA 20	1
	0370404	STATOR, GA 16	1
	0370406	STATOR, GA 12	1
18	0150410	STATOR VANE	4
19	0370420	STATOR VANE SPRING	8
20	0370300PC	ROTOR, PC	1
	0370300PL	ROTOR, PL	1
21	0370313PC	ROTOR VANE, S	10
	0370316PL	ROTOR VANE, L	10
22	1250320	ROTOR VANE SPRING, OUTER	20
23	1250321	ROTOR VANE SPRING, INNER	20
24	0370720	NEEDLE BEARING	1
25	0370885	REAR HOUSING, A, PC	1
26	0370901	BOLT	8
27	0370827	O-RING, THRU SEAL PLATE	1
28	0370178	SEAL, TCN	1
29	0370826	SEAL PLATE, TCN	1
30	0370816	SNAP RING, REAR	1

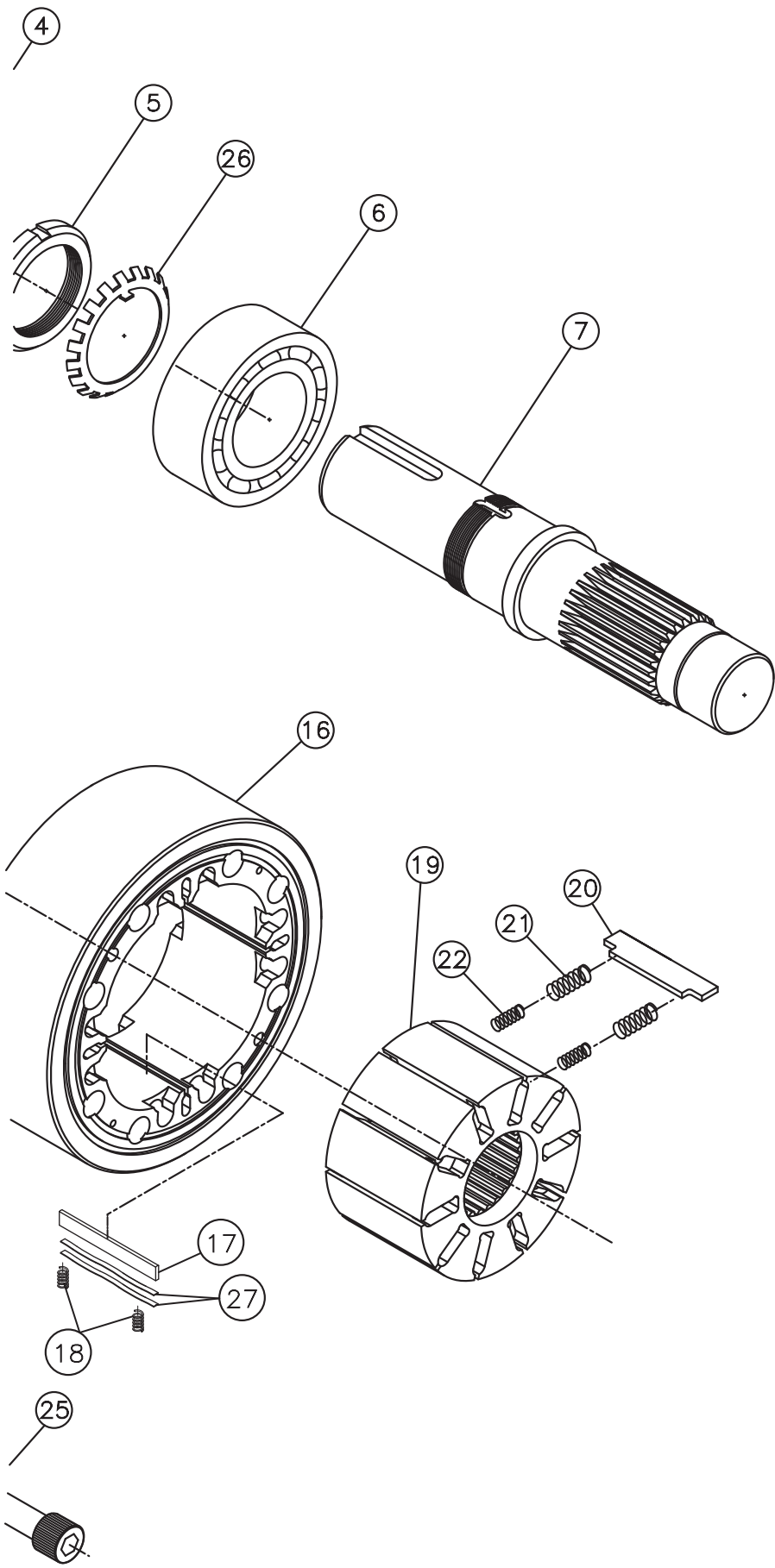

SERIES 57 EXP. VIEW, STD. 'A' STYLE

ITEM	PART NO.	DESCRIPTION	QTY
1	1250117	BOLT, SEAL PLATE	6
2	0370154	SEAL PLATE	1
3	0370175	SEAL, SHAFT, TCN	1
4	0370142	O-RING, SEAL PLATE	1
5	0370708	LOCKNUT, THRUST	1
6	0370710	BALL BEARING	1
7	0370741	SHAFT, KEYED	1
	0370748	SHAFT, SPLINED	1
8	0371123	FRONT HOUSING, A, PC	1
9	0370811	O-RING, THERMAL, INNER	2
10	0371829	O-RING, THERMAL, MIDDLE	2
11	0370810	O-RING, THERMAL, OUTER	2
12	0370610	O-RING, MAIN	4
13	0150620	PLATE SCREW	4
14	0370618	PLATE, TIMING, PC	2
15	0370431	DOWEL PIN	4
16	0370407	STATOR, GA 55.5	1
	0370408	STATOR, GA 48	1
17	0370410	STATOR VANE	4
18	0150420	STATOR VANE SPRING	8
19	0370303PC	ROTOR, S	1
	0370303PL	ROTOR, L	1
20	0370314PC	ROTOR VANE, S	10
	0370315PL	ROTOR VANE, L	10
21	1250320	ROTOR VANE SPRING, OUTER	20
22	1250321	ROTOR VANE SPRING, INNER	20
23	0370720	NEEDLE BEARING	1
24	0370883	REAR HOUSING, A, PC	1
25	0370931	BOLT	8
26	0370709	LOCK WASHER, THRUST	1
27	1250442	WAVE SPRING	8

Removal of 37 Series Seal Carrier Plate



1

1) Remove snap ring.

WARNING:
Use caution when removing snap ring. If released accidentally, it can become an airborne hazard.



5

(Remove only as necessary)
Bearings from both shafts can now be removed in the following manner:

- 37 Series
- 1) Remove snap ring from shaft.
 - 2) Press shaft out of bearing.
- 57 Series
- 1) Unfold tab on lock washer.
 - 2) Unscrew lock nut with hook style spanner wrench.
 - 3) Press shaft out of bearing.



2

- 1) Pry out shaft seal plate with two screwdrivers.
- 2) Remove seal plate o-ring from groove in bearing bore.

NOTE:
The shaft seal on a std. motor is pressed in and can be removed in the reverse manner.

Removal of Front Housing and Rotating group



6

Both the 37 and 57 motors should be positioned as shown in a suitable mount to hold the unit during main bolt removal and subsequent disassembly. To ensure proper orientation during assembly, use a laquer paint pen to mark a line down the side of the motor.

Removal of 57 Series Seal Carrier Plate



3

- 1) Loosen and remove 6 each 3/8-16 bolts.
- 2) Lift up on the seal plate. Protect the shaft seal from being cut by the keyway (keyed shaft) by placing a thin strip of metallic tape over the shaft. Smooth any burrs that may tear or snag the seal.



7

Loosen and remove the eight 5/8-11 main bolts. Any bolt heads showing heavy corrosion or signs of rounding of the hex form should be replaced.

Shaft Disassembly



4

A 1/2-13 tapped hole is included in the end of the 37 and 57 series shafts. A slide hammer shaft puller can be attached using this tapped hole in order to remove the shaft from the motor.



8

Remove rear housing as shown. Remove o-rings from housing and dowel pins from the rotating group.



Remove rotating group from front housing as shown. Place the rotating group on a clean surface for disassembly and inspection. Remove dowel pins and o-rings from the housing.

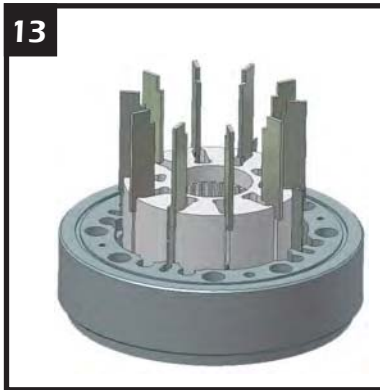

1) Remove the rotor.
2) Remove both the rotor and the stator vanes.
NOTE: On motors manufactured prior to 1987, rotor vane slots and rotor vanes should be numbered so that vanes can be reassembled in the same vane slot.
3) Separate parts and rinse in solvent tank.

Disassembly of Rotating group

Inspection and Replacement of parts

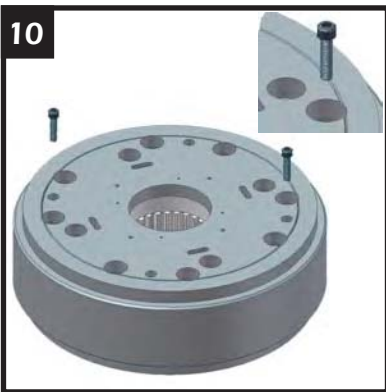

1) Place cartridge on any object which will hold it off the table.
2) Remove two each 10-32 plate screws.
3) Remove timing plate.



Inspect all parts and replace any parts which obviously show excessive wear or damage. We recommend changing all springs and seals whenever the motor has been disassembled.



Using a small screwdriver or pick, remove o-ring and all rotor and stator springs.
Note: Some 57 series rotating groups may contain additional "wave" springs in the stator vane slot (see inset).

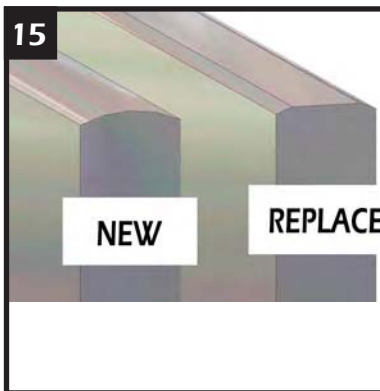

VANES:
Normal wear results in slight flattening of vane tips which does not impair motor performance. Replace vane if radius is reduced by 50%. Clearance between the rotor vane and rotor vane slot varies with the vane selection. The design allows the vane to "lean" slightly in the slot, providing the required mechanical seal.



1) Replace plate on rotor/stator cartridge.
2) Turn rotor/stator cartridge over.
3) Repeat steps 10 & 11.



PLATES:
Normal wear results in marking or polishing of the timing plate surface, which does not impair motor performance. Replacement of the timing plate is required if any smearing, galling, or heat cracks are present.

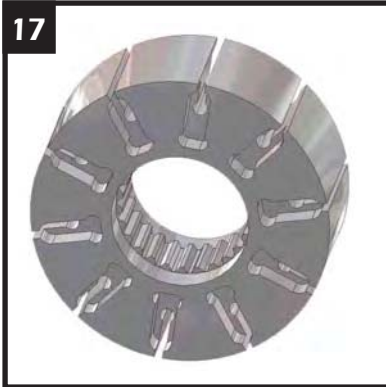

17

ROTOR: Normal wear results in polishing of rotor faces which does not impair motor performance. Examine the rotor vane slots closely. Polishing down in the slots is normal, but if there is any indication of a "pocket" forming in the wall of the slot, the rotor should be replaced.

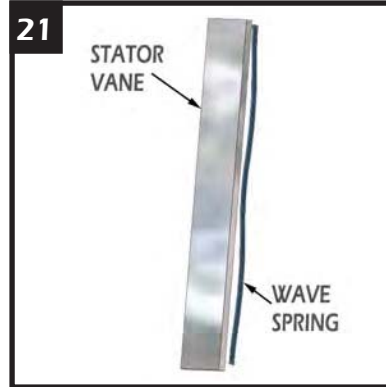

21

Wave springs in the 57 series do not need to be replaced. Certain model codes do not contain wave springs, while other model codes may contain two per vane. Place the stator vane and wave spring in the stator vane slot simultaneously. Note orientation as shown. Do not let the coil spring loop catch between the wave spring and vane.

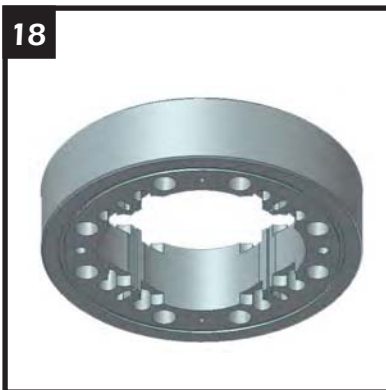

18

STATOR: Normal wear results in polishing of cam form which does not impair motor performance. Noticeable wear may be apparent along the corner of one side of the stator vane slot. This does not necessarily require replacement of the stator, but may slightly affect volumetric efficiency.

Assembly of Motor



22

Using a medium India honing stone, lightly dress all machine surfaces to remove any raised metal or burrs. Pay particular attention to the front and rear housing machined faces. Rough handling can cause raised surfaces near the O.D. of the housings which will prevent proper seating of the timing plates to the machined surfaces of the housing. NOTE: The pedestal surface (center of the front and rear housing containing two or three o-rings) is .002-.003 below the outer machined surface. Dress these surfaces independently.

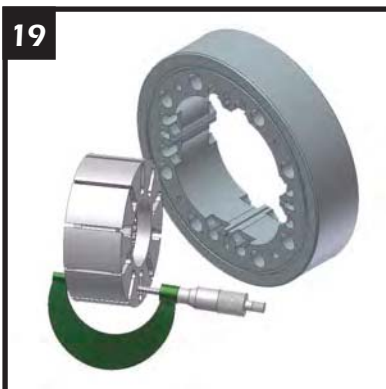

19

Measure the rotor and stator length to the fourth decimal point and supply measurement when ordering rotor, stator, or vanes.



23

Assemble the motor by reversing the previous procedures. Insure that the main body and pedestal o-rings are held in place by using an adequate amount of grease in the o-ring grooves. Line up the housings and rotating group with the paint line made on the motor in step 6.

Assembly of Rotor / Stator Cartridge



20

1) Reverse the procedures in steps 13, 12, 11, and 10. Before installing timing plate onto completed sides of rotating group, pour a small amount of hydraulic oil onto rotor surface.
 2) NOTE: Make sure that the radiused edge of each stator vane points to the rotor and the radiused edge of each rotor vane points to the stator.
 3) NOTE: Make sure springs are seated in the bottom of the spring pocket in both the rotor and stator.
 NOTE: Do not allow the coil of any spring catch on the edge of the rotor or stator vanes.



24

Grease the threads of the 5/8-11 bolts and insert into motor. Set torque wrench to 200 ft. lbs. and tighten in a star pattern. Install shaft, seal plate and snap ring in reverse order of previous procedures. Rotate shaft to insure no binding is present.

WARNING: RINEER RECOMMENDS FOLLOWING ALL STANDARD SHOP SAFETY PRACTICES SPECIFICALLY INCLUDING WEARING OF EYE PROTECTION.

PROCEDURE FOR INSTALLING LOCKNUT 57 SERIES ONLY

1. Clean the shaft, locknut (part no. 0370708), and the thread area before assembly.
2. Prior to assembly, test the thread fit by assembling the locknut onto the shaft threads several turns. Insure working thread form. Remove locknut.
3. Press the bearing onto the shaft according to proper pressing procedures (see other details for information).
4. Place lockwasher (part no. 0370709), with the tang pointing down to match the slot in shaft, onto the shaft, flat on top of bearing.
5. Assemble locknut onto the shaft until it is tight against lockwasher and bearing. If needed, tighten the locknut until it is squarely aligned with one of the tabs on the lockwasher.
6. Bend one tab only into the slot on the locknut to prevent the locknut from loosening on the shaft. Do not attempt to bend a partially aligned tab. (See details below.)

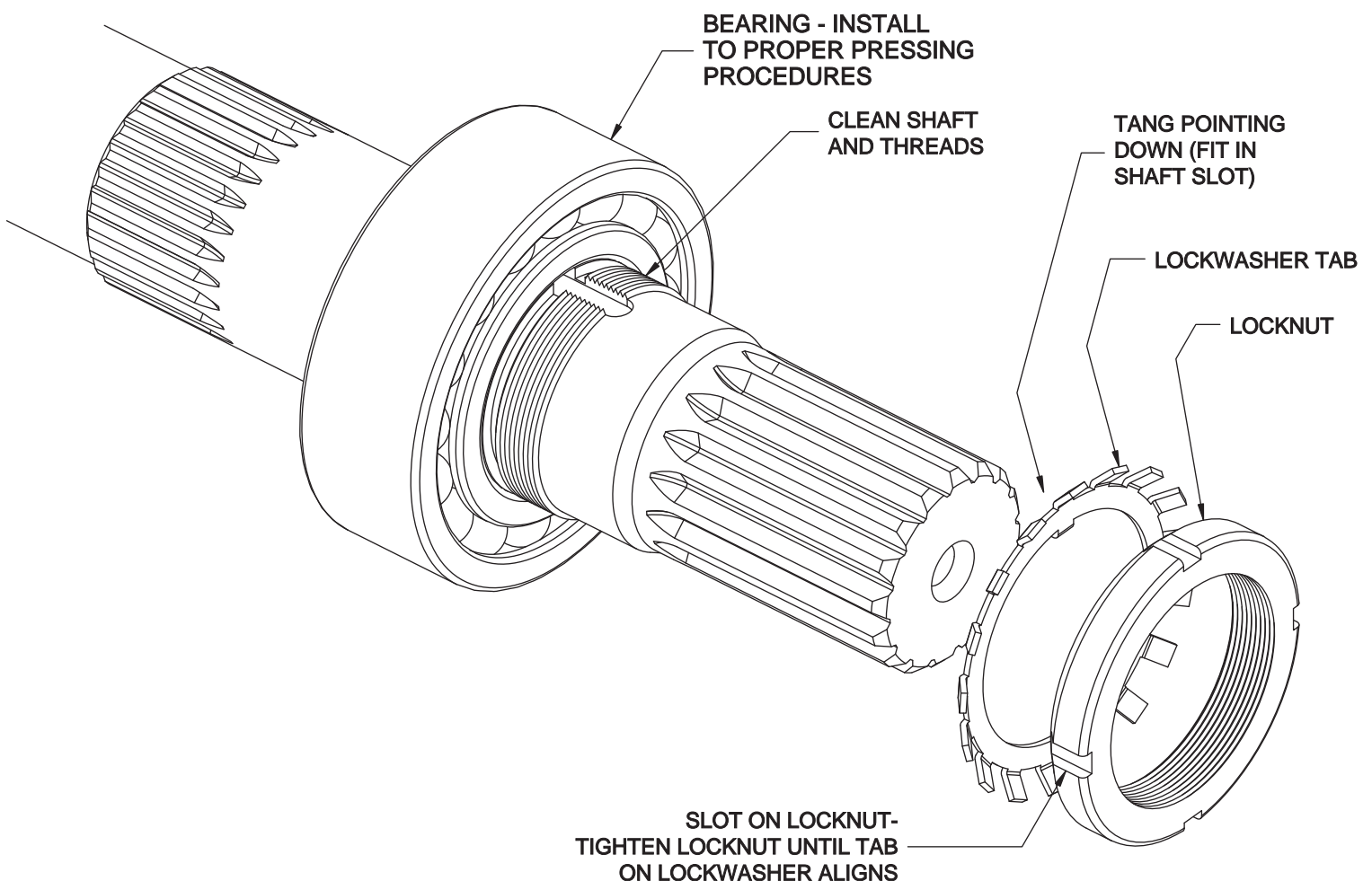

Information:

Bolt Torque -

Main Bolts (5/8-11): 200 ft. lbs.

Seal Plate (3/8-16)

(57 series only): 45 ft. lbs.

Grease used for bolt threads
and o-ring retention:

Pennzoil 707L RED

Shaft seal assembly lube:

Mobilgrease special
with Moly

Seal Kits:

Standard 37 series seal kit

#0370973

Standard 37 thru-key seal kit

#0370962

Standard 57 series seal kit

#0370963

37

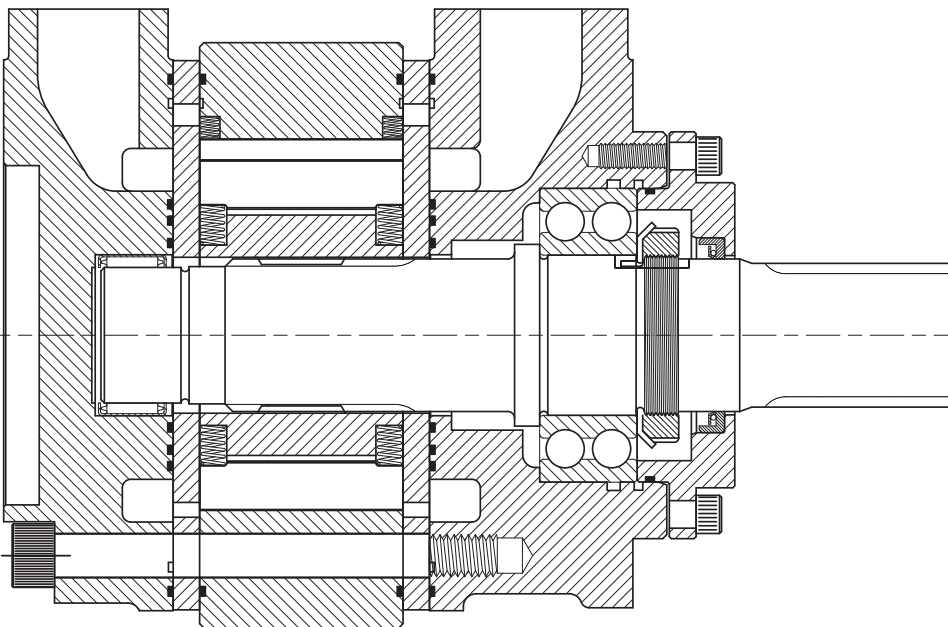
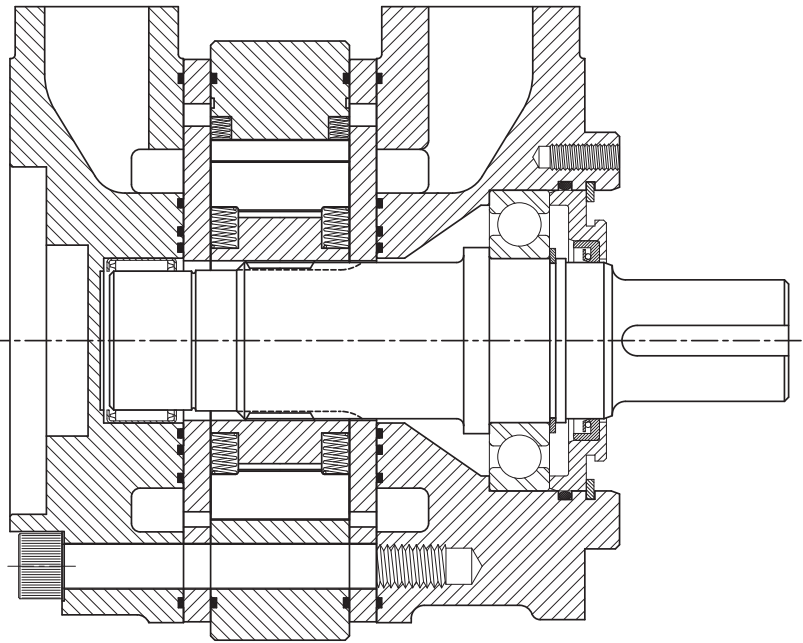

57