

MANNESMANN REXROTH	Variable Displacement Motor AA6VM (A6VM)		RA 91 604/08.97
	Series 6, for open and closed circuits Axial tapered piston - bent axis design		
Sizes 28...1000	Nominal Pressure up to 5800 psi (400 bar)	Peak Pressure up to 6500 psi (450 bar)	Replaces: RA 91604/07.95 RA 91603/05.95

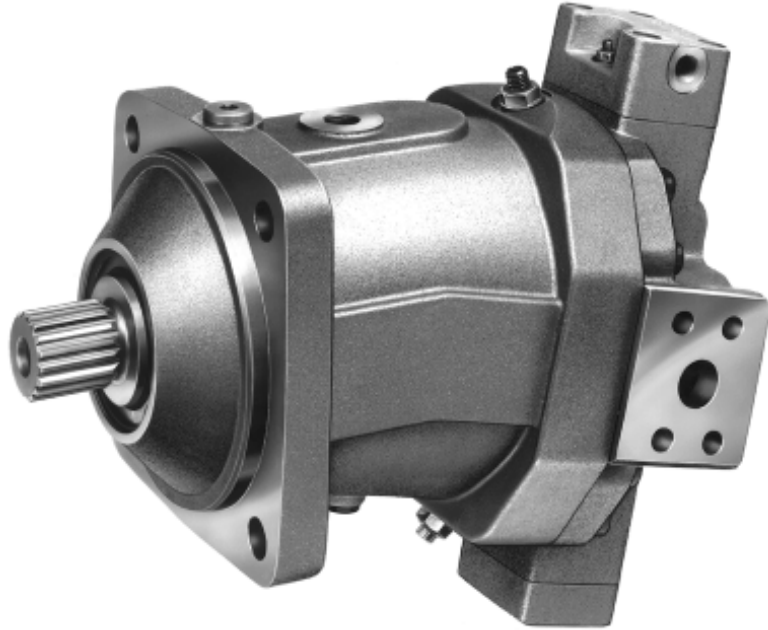

Variable displacement motor with axial piston rotary group of bent axis design, for hydrostatic drives in open and closed circuits.

The motor is suitable for both mobile and industrial applications. The wide control range of the variable displacement motor allows it to meet the requirements of high speed and high torque.

The displacement is infinitely variable in the range $V_{g \max}$ to $V_{g \min} = 0$.

Output speed is proportional to flow and inversely proportional to displacement. The output torque increases with the pressure drop between the high and low pressure sides and with increasing displacement.

- Wide control range for hydrostatic drives
- Various control and regulating devices
- Cost saving through elimination of gearbox and possibility of using smaller pumps
- Compact, robust bearing system with long service life
- Low unit power
- Good starting characteristics
- Low inertia
- Wide swivel range

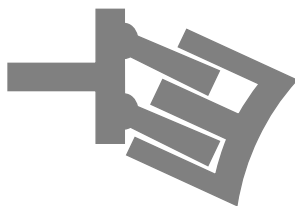

Variable Displacement Motor AA6VM (A6VM)

Ordering Code / Standard Program

Hydraulic fluid

Table for Hydraulic fluid selection: Petroleum oil (no code), HF-fluids sizes 28...200 (no code), HF-fluids sizes 250...1000 (only in connection with drive shaft bearings "L")

Axial piston unit

Table for Axial piston unit selection: Bent axis design, variable displacement; sizes 28, 55, 80, 107, 140, 160, 200, 250, 355, 500, 1000; SAE/ISO versions

Drive shaft bearings

Table for Drive shaft bearings selection: Mechanical bearings (no code), Long-Life bearings; sizes 28...200, 250...500, 1000

Mode of operation

Table for Mode of operation selection: Motor (Plug-in motor A6VE see RE 91606)

Size

Table for Size selection: size Displacement Vg,max, cm³/rev, in³/rev; sizes 28, 55, 80, 107, 140, 160, 200, 250, 355, 500, 1000

Control device

Main control device table with multiple rows: Hydraulic control (HD), pilot pressure related; Hydraulic two-position control (HZ); Electrical control (EP), with proportional solenoid; Electrical two-position control (EZ), with switching solenoid; Automatic control (HA), high pressure related; Model with/without pressure increase; Override; Hydraulic control, speed related (DA); pSi/pHD = 5/100; pSi/pHD = 8/100.

Hydraulic fluid

Axial piston unit

Drive shaft bearings

Mode of operation

Size

Control device

Series/Index

Direction of rotation

Setting range for displacement 1)

Table for Setting range for displacement: Vg,min = 0 to 0,8 Vg,max; Vg,min = 0 to 0,4 Vg,max; Vg,min = 0,4 Vg,max to 0,8 Vg,max

Seals

Table for Seals selection: NBR (nitril-caoutchouc), FPM (fluor-caoutchouc)

Shaft end

Table for Shaft end selection: SAE-Version, ISO-Version, Parallel shaft with key DIN 6885

Mounting flange

Table for Mounting flange selection: SAE-Version, ISO-Version

Service ports

Table for Service ports selection: SAE-Version (AA6VM), ISO-Version (A6VM) for various port configurations

Valves

Table for Valves selection: without valve, with flushing and boost pressure valve, with built-on motion control valve

Speed sensor

Table for Speed sensor selection: without speed sensor, prepared for speed sensor

Swivel angle indicato

Table for Swivel angle indicato selection: without swivel angle indicator, with optical swivel angle indicator, with electronic swivel angle indicator

Start of control

Table for Start of control selection: at Vg,sm (standard for HA), at Vg,max (standard for HD, HZ, EP, EZ, DA)

1) indicate in the order in clear text: sizes 28...200 Vg,min = ... in³ (cm³); sizes 250...1000 Vg,min = ... in³ (cm³), Vg,max = ... in³ (cm³)
2) only possible in connection with controls HD, HA1, HA2; metric threads!

• = available ○ = in preparation - = not available

Technical Data

Hydraulic fluid

We request that before starting a project detailed information about the choice of pressure fluids and application conditions are taken from our catalogue sheets RA 90220 (petroleum oil), RA 90221 (environmentally acceptable hydraulic fluids) and RA 90223 (fire resistance fluids, HF).

When using HF- or environmentally acceptable hydraulic fluids possible limitations for the technical data have to be taken into consideration. If necessary please consult us or your fluid supplier (please indicate type of the hydraulic fluid used for your application on the order sheet).

Operating viscosity range

In order to obtain optimum efficiency and service life, we recommend that the operating viscosity (at operating temperature) be selected from within the range:

Optimum operating viscosity (v_{opt})...80-170 SUS (16...36 mm²/s)

referred to the loop temperature (closed circuit) or reservoir temperature (open circuit).

Viscosity limits

The limiting values for viscosity are as follows:

Sizes 28...200

$v_{min} = 42$ SUS (5 mm²/s)
short term at a max. permissible temp. of $t_{max} = 240^{\circ}\text{F}$ (115 $^{\circ}\text{C}$)

$v_{max} = 7400$ SUS (1600 mm²/s)
short term on cold start ($t_{min} = -40^{\circ}\text{F}/-40^{\circ}\text{C}$)

Sizes 250...1000

$v_{min} = 60$ SUS (10 mm²/s)
short term at a max. permissible leakage oil temperature of $t_{max} = 195^{\circ}\text{F}$ (90 $^{\circ}\text{C}$)

$v_{max} = 4600$ SUS (1000 mm²/s)
short term on cold start ($t_{min} = -13^{\circ}\text{F}/-25^{\circ}\text{C}$)

Please note that the max. fluid temperature is also not exceeded in certain areas (for instance bearing area).

At temperatures of -13°F up to -40°F (-25°C up to -40°C) special measures may be required for certain installation positions. Please contact us for further information.

Selection diagram

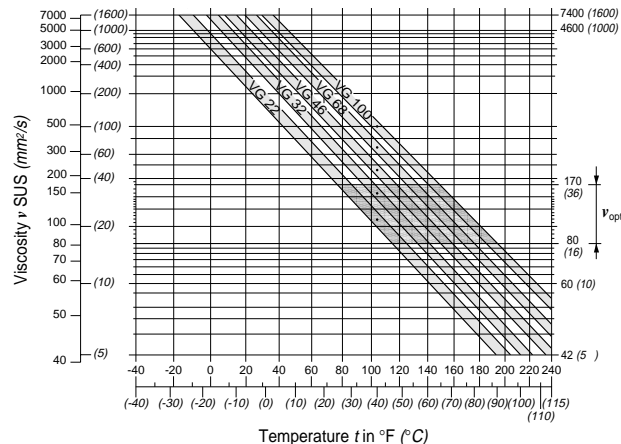

Notes on the selection of the hydraulic fluid

In order to select the correct fluid, it is necessary to know the operating temperature in the loop (closed circuit) or the reservoir temperature (open circuit) in relation to the ambient temperature.

The hydraulic fluid should be selected so that within the operating temperature range, the operating viscosity lies within the optimum range (v_{opt}) (see shaded section of the selection diagram). We recommend that the highest possible viscosity range should be chosen in each case.

Example: At an ambient temperature of X° the operating temperature (closed circuit: loop temperature; open circuit: reservoir temperature) is 140°F (60°C). Within the optimum operating viscosity range (v_{opt} ; shaded area), this corresponds to viscosity grades VG 46 or VG 68. VG 68 should be selected.

Important: The leakage oil (case drain oil) temperature is influenced by pressure and motor speed and is always higher than the circuit temperature or the reservoir temperature. However, at no point in the system may the temperature exceed 240°F (115°C) for sizes 28...200 or 195°F (90°C) for sizes 250...1000.

If it is not possible to comply with the above condition because of extreme operating parameters or high ambient temperatures we recommend housing flushing via port U or use of a flushing valve (see page 5). Please consult us.

Filtration

The finer the filtration the better the achieved purity grade of the pressure fluid and the longer the life of the axial piston unit. To ensure the functioning of the axial piston unit a minimum purity grade of:

- 9 to NAS 1638
- 6 to SAE
- 18/15 to ISO/DIS 4406 is necessary.

At very high temperatures of the hydraulic fluid (195°F to max. 240°F / 90°C to max. 115°C , not perm. for sizes 250...1000) at least cleanliness class

- 8 to NAS 1638
- 5 to SAE
- 17/14 to ISO/DIS 4406 is necessary.

If above mentioned grades cannot be maintained please consult us.

Direction of flow

clockwise rotation counter-clockwise rotation

A to B **B to A**

Speed range

There is no limitation on minimum speed n_{min} . If uniformity of rotation is required, however, speed n_{min} should not be allowed to fall below 50 rpm. See table on page 6 for max. permissible speeds.

Installation position

Optional. The motor housing must be filled with fluid prior the commissioning, and must remain full whenever it is operating. For extensive information on installation position, please consult our data sheet RA 90 270 before completing your design work.

Variable Displacement Motor AA6VM (A6VM)

Technical Data

Case drain pressure

Shaft seal ring **FPM** (fluor-caoutchouc)

The lower the speed and the case drain pressure the higher the life expectation of the shaft seal.

The values shown in the diagram are permissible loads of the seal ring and shall not be exceeded.

At stationary pressure loads in the range of the max. admissible leakage pressure a reduction of the life experience of the seal ring will result.

For a short period ($t < 5$ min.) pressure loads up to 75 psi (5 bar) independent from rotational speeds are permissible respectively for sizes 28...200.

Sizes 28...200

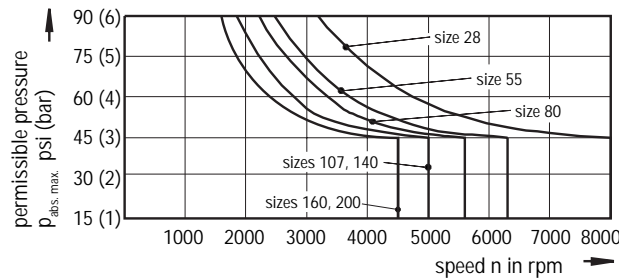

Sizes 250...1000

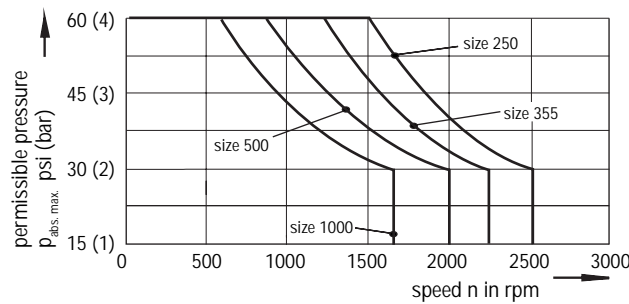

Special operation conditions may require limitations of these values.

Note:

- max. permissible motor speeds are given in the table on page 6.

- max. permissible housing pressure

sizes 28...200: $p_{abs,max} = 90$ psi (6 bar)

sizes 250...1000: $p_{abs,max} = 60$ psi (4 bar)

The pressure in the housing must be the same as or greater than the external pressure on the shaft seal.

Long-life bearings (sizes 250...1000)

For long service life and HF fluids.

Special features:

The external dimensions of the axial piston pump do not vary from the standard.

The long-life bearing set may be subsequently built into available axial piston pumps.

The drain case port must always be open.

It is recommended that the bearings are flushed via port U.

Flushing and boost pressure valve

The flushing and boost pressure valve (closed circuits) is set at a fixed pressure of 230 psi (16 bar) and serves to maintain the minimum boost pressure (set primary valve accordingly). Dependend on the control device and motor size, the valve is mounted onto the variable motor or integrated in the control device (see page 35).

A quantity of hydraulic fluid, determined by the orifice fitted, is drawn off from the low pressure side and passed into the motor housing, from where it is led off to reservoir together with the leakage fluid. The fluid thus taken from the circuit must be replaced with cooled oil by means of the boost pump.

Different flushing volumes can be selected by means of orifices.

Flow * (for low pressure $\Delta p = 365$ psi/25 bar)

Size	Volume	Orifice-No.
28, 55	0.9 gpm (3,5 L/min)	09651766/503.12.01.01
80	1.3 gpm (5 L/min)	09419695/503.12.01.01
107	2.1 gpm (8 L/min)	09419696/503.12.01.01
160, 200	2.6 gpm (10 L/min)	09419697/503.12.01.01
250	2.6 gpm (10 L/min)	
355	4.2 gpm (16 L/min)	
500	5.3 gpm (20 L/min)	
1000	6.6 gpm (25 L/min)	

* Standard flushing volumes

(for sizes 28...200 flushing volumes of 0.9 - 2.6 gpm (3,5 - 10 L/min) can be supplied. If a flushing volume different from the standard flushing volume is required, please indicate the requested orifice in clear text when ordering.)

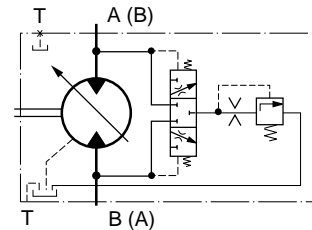

Operating pressure range

Maximum pressure at port A or B (Pressure data to DIN 24312)

Sizes 28...200

Nominal pressure p_N	5800 psi (400 bar)*
Peak pressure p_{max}	6525 psi (450 bar)*

*) size 80: $p_N = 5100$ psi (350 bar), $p_{max} = 5800$ psi (400 bar)
Attention: shaft end **Z** and **S** with drives of radial force loads at the drive shaft (pinion V-belt drives) necessitate reduction of the nominal pressure to $p_N = 4570$ psi (315 bar), size 80: $p_N = 2900$ psi (200 bar). Please contact us.

Sizes 250...1000

Nominal pressure p_N	5100 psi (350 bar)
Peak pressure p_{max}	5800 psi (400 bar)

With pulsating loads above 4570 psi (315 bar) we recommend using the model with splined shaft (sizes 250...1000).

The summ of the pressures at ports A and B may not exceed 10000 psi (700 bar).

Variable Displacement Motor AA6VM (A6VM)

Table of values (theoretical values, without considering η_{mh} and η_v ; values rounded)

Size			28	55	80	107	140	160	200	250	355	500	1000
Displacement	$V_{g\ max}$	in ³ /rev	1.71	3.34	4.88	6.53	8.54	9.76	12.20	15.25	21.66	30.51	61.02
		cm ³ /rev	28,1	54,8	80	107	140	160	200	250	355	500	1000
	$V_{g\ 0}^{1)}$	in ³ (cm ³)/rev	0	0	0	0	0	0	0	0	0	0	0
Max. speed	$n_{max\ at\ V_{g\ max}}$	rpm	5300	4200	3750	3300	3150	3000	2750	2500	2240	2000	1600
	$n_{max,\ intermittent\ at\ V_{g\ max}^{2)}$	rpm	5850	4600	4100	3650	3450	3300	3000	2500	2240	2000	1600
	$n_{max\ at\ V_g < V_{g,1}}$	rpm	8000	6300	5600	5000	4700	4500	4100	3300	2950	2650	2100
	$V_{g,1}$	in ³ /rev	1.16	2.26	3.30	4.33	5.68	6.53	8.18	11.59	16.48	23.49	46.50
		cm ³ /rev	19	37	54	71	93	107	134	190	270	385	762
	$n_{max\ at\ V_{g\ 0}}$	rpm	8800	7100	6300	5600	5200	5000	4500	3300	2950	2650	2100
Max. perm. flow	$q_{V\ max}$	gpm	39.4	60.8	79.3	93.3	116.5	126.8	145.3	165.1	210.0	264.2	422.7
		L/min	149	230	300	353	441	480	550	625	795	1000	1600
Torque constants	$T_k\ at\ V_{g\ max}$	lb-ft/psi	0.023	0.044	0.065	0.086	0.113	0.129	0.162	0.202	0.287	0.405	0.810
		Nm/bar	0.446	0.87	1.27	1.70	2.23	2.54	3.18	3.98	5.65	7.96	15.92
Max. torque	$T_{max}\ at\ V_{g\ max}^{3)}$	lb-ft	131.3	256.7	376.1	500.8	657.1	749.3	938.9	1025.9	1458.8	2054	4109
		Nm	178	348	510	679	891	1016	1273	1391	1978	2785	5571
Case volume		gal	0.13	0.20	0.32	0.40	0.48	0.63	0.71	0.79		1.85	
		L	0,5	0,75	1,2	1,5	1,8	2,4	2,7	3,0		7,0	
Moment of inertia about drive axis	J	lbs-ft ²	0.033	0.100	0.190	0.301	0.491	0.600	0.838	1.448	2.420	4.224	13.05
		kgm ²	0,0014	0,0042	0,0080	0,0127	0,0207	0,0253	0,0353	0,061	0,102	0,178	0,550
Weight (approx.)	m	lbs	35.3	57.3	75.0	103	132	141	176	198	375	463	952
		kg	16	26	34	47	60	64	80	90	170	210	432

- 1) The minimum displacement $V_{g\ min}$ is infinitely adjustable between $V_{g\ 0}$ and $0,8 \cdot V_{g\ max}$.
Indicate in the order: $V_{g\ min} = \dots \text{ cm}^3$ (note for sizes 250...1000: $V_{g\ min}$ is set to $0,2 \cdot V_{g\ max}$ when there is no indication in the order!)
- 2) Intermittent max. speed: overspeed at discharge and overtaking travel operation, $t < 5$ sec. and $\Delta p < 2175$ psi (150 bar)
- 3) Sizes 28...200: $\Delta p = 5800$ psi (400 bar); sizes 250...1000: $\Delta p = 5100$ psi (350 bar)

Permissible displacement, speed related

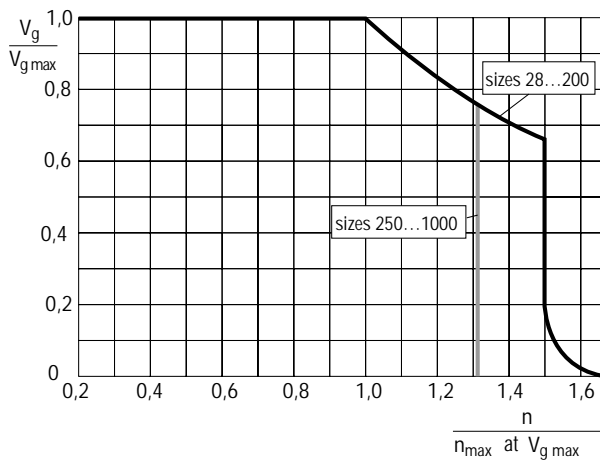

Calculation of size

$$\text{Flow } q_v = \frac{V_g \cdot n}{231 \cdot \eta_v} \text{ gpm} \quad \left(q_v = \frac{V_g \cdot n}{1000 \cdot \eta_v} \text{ L/min} \right)$$

$$\text{Output Speed } n = \frac{q_v \cdot 231 \cdot \eta_v}{V_g} \text{ rpm} \quad \left(n = \frac{q_v \cdot 1000 \cdot \eta_v}{V_g} \text{ rpm} \right)$$

$$\text{Output Torque } T = \frac{V_g \cdot \Delta p \cdot \eta_{mh}}{24 \cdot \pi} \text{ lb-ft} \quad \left(T = \frac{V_g \cdot \Delta p \cdot \eta_{mh}}{20 \cdot \pi} \text{ Nm} \right)$$

$$\text{Output Power } P = \frac{T \cdot n}{5252} = \frac{q_v \cdot \Delta p \cdot \eta_t}{1714} \text{ HP}$$

$$\left(P = \frac{T \cdot n}{9549} = \frac{q_v \cdot \Delta p \cdot \eta_t}{600} \text{ kW} \right)$$

V_g = geometric displacement per rev. - in³ (cm³)
 Δp = pressure differential - psi (bar)
 η_v = volumetric efficiency
 η_{mh} = mech.-hyd. efficiency
 η_t = total efficiency ($\eta_v \cdot \eta_{mh} = \eta_t$)

Variable Displacement Motor AA6VM (A6VM)

Output drive

Permissible axial and radial loading on drive shaft. The values given are maximum values and not permissible for continuous operation.

Size		28	55	80	107	140	160	200	250	355	500	1000	
a	in	0.49	0.59	0.69	0.79	0.89	0.89	0.98	1.61	2.07	2.07	2.66	
	mm	12.5	15	17.5	20	22.5	22.5	25	41	52.5	52.5	67.5	
$F_{q\ max}$	lbf	1280	2347	1911	3434	4003	4568	5147	270 ¹⁾	337 ¹⁾	427 ¹⁾		
	N	5696	10440	8500	15278	17808	20320	22896	1200 ¹⁾	1500 ¹⁾	1900 ¹⁾		
$\pm F_{ax\ max}$	lbf	$+ F_{ax\ max}$	71	112	160	202	231	252	281	899	1124	1405	2248
		$- F_{ax\ max}$	71	112	160	202	231	252	281	270	337	427	584
	N	$+ F_{ax\ max}$	315	500	710	900	1030	1120	1250	4000	5000	6250	10000
		$- F_{ax\ max}$	315	500	710	900	1030	1120	1250	1200	1500	1900	2600
$\pm F_{ax\ perm.}/psi$	lbf/psi	0.07	0.12	0.15	0.18	0.21	0.23	0.26	²⁾	²⁾	²⁾	²⁾	
$\pm F_{ax\ perm.}/bar$	N/bar	4.6	7.5	9.6	11.3	13.3	15.1	17.0	²⁾	²⁾	²⁾	²⁾	

¹⁾ Axial piston unit in stationary or in bypass operation, please contact us when appearing higher forces!

²⁾ Please contact us!

Code explanation

a = distance of F_q from shaft shoulder

$F_{q\ max}$ = max. perm. radial force at distance a (at intermittent operation)

$\pm F_{ax\ max}$ = max. perm. axial force when stationary or when axial piston unit is running at zero pressure

$\pm F_{ax\ perm.}/psi$ = perm. axial force/psi operating pressure

$\pm F_{ax\ perm.}/bar$ = perm. axial force/bar operating pressure

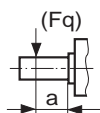

The direction of the max. axial force must be noted by sizes 28...200

$- F_{ax\ max}$ = increased bearing life

$+ F_{ax\ max}$ = reduced bearing life (avoid if possible)

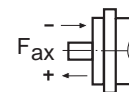

Speed sensor (D)

Version AA6VM (A6VM) . . . D ("with provisions for speed sensor") includes toothed collar on the rotary group.

A speed-proportional signal is produced by means of the rotating, toothed rotary group which can be picked up by a suitable sensor and fed back for evaluation.

The speed sensor can be screwed into the upper drain port. An additional adapter piece (included in supply) is necessary for the drain ports sizes 55-200 in order to install the speed sensors (thread metric M18x1,5).

Size	28	55	80	107	140	160	200
no. of teeth	42	54	58	67	72	75	80

The speed sensor is not included in standard supply;

Suitable sensors:

- Inductive impulse detector ID (see RA 95038)

- Hall effect speed sensor HD (see RA 95042);

order separately!

speed sensor (ID/HD)

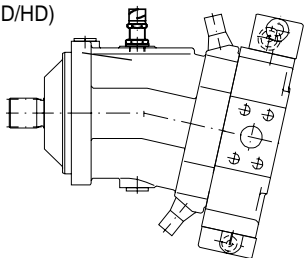

Optimal force direction of F_q (valid for sizes 28...200)

By means of appropriate force directions of F_q the bearing load caused by inside rotary group forces can be reduced. An optimal life expectation of the bearing can be reached.

Gear drive

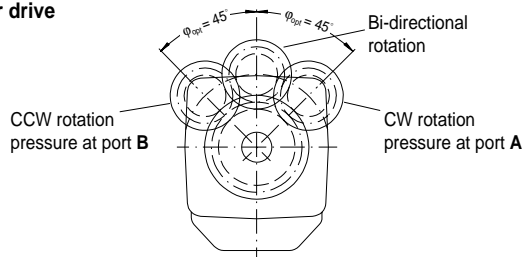

V-belt drive

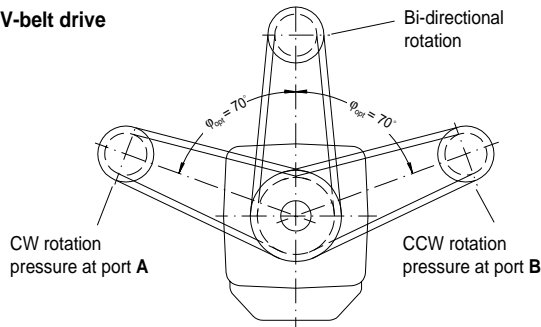

HD Hydraulic Control, Pilot Pressure Related

The pilot pressure related hydraulic control allows infinite variation of the motor displacement in relation to a pilot pressure signal. The control function is proportional to the pilot pressure applied at port X.

HD1 Pilot pressure increase 145 psi (10 bar)

- sizes 28...200 ($V_{g\ min} = 0$ to $V_{g\ max}$) $\Delta p_s = 145$ psi (10 bar)
- sizes 250...1000 ($V_{g\ min} = 0,2 V_{g\ max}$ to $V_{g\ max}$) $\Delta p_s = 145$ psi (10 bar)

Start of control, setting range:

- sizes 28...1000 30 - 290 psi (2 - 20 bar)

Standard setting: start of control at 45 psi (3 bar)

end of control at 190 psi (13 bar)

HD2 Pilot pressure increase 365 psi (25 bar)

- sizes 28...200 ($V_{g\ min} = 0$ to $V_{g\ max}$) $\Delta p_s = 365$ psi (25 bar)
- sizes 250...1000 ($V_{g\ min} = 0,2 V_{g\ max}$ to $V_{g\ max}$) $\Delta p_s = 365$ psi (25 bar)

Start of control, setting range:

- sizes 28...1000 75 - 725 psi (5 - 50 bar)

Standard setting: start of control at 145 psi (10 bar)

end of control at 510 psi (35 bar)

When ordering please state required start of control in clear text, e.g. start of control at 45 psi (3 bar).

Circuit diagram:

Hydraulic control, pilot pressure related HD1, HD2

Sizes 28...200

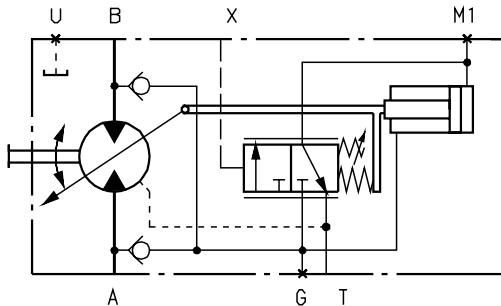

Sizes 250...1000

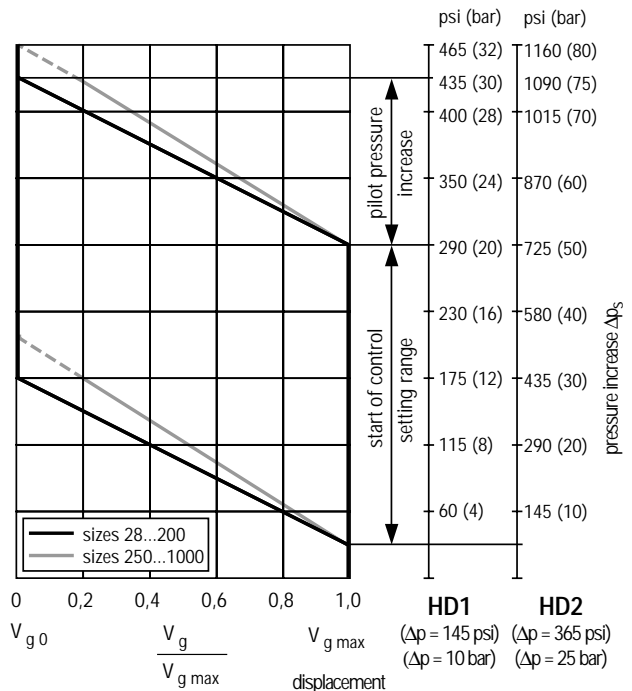
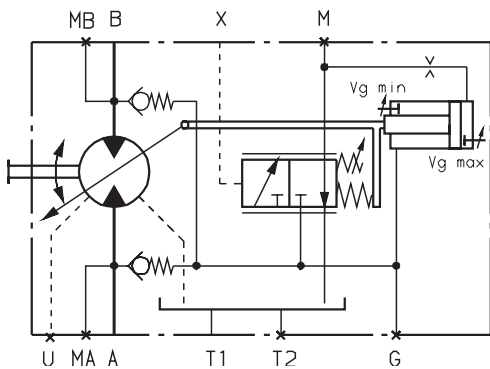

Standard version:

- start of control at $V_{g\ max}$ (max. torque, min. speed)
- end of control at $V_{g\ min}$ (min. torque, max. perm. speed)

Max. perm. pilot pressure 1450 psi (100 bar)

Because of internal leakage, there is a leakage flow of approx. 0.08 gpm (0,3 L/min.) at port X.

To prevent an influence on the characteristic, leakage flow has to be led into the tank through the control device.

Unit dimensions control HD, see page 22...32

Variable Displacement Motor AA6VM (A6VM)

Variation: Constant pressure control (HD.D)

The constant pressure control is superimposed on the HD function. Should system pressure rise as a result of the load torque or reduction of the motor swivel angle, when the setting of the constant pressure control is reached the motor is swivelled out to a higher angle.

As a result of the increased displacement and consequent pressure reduction, the control deviation is eliminated. By increasing the displacement the motor produces a higher torque at a constant pressure.

Setting range of constant pressure control valve:

sizes 28...200 _____ 1160 - 5800 psi (80 - 400 bar)

sizes 250...1000 _____ 1160 - 5100 psi (80 - 350 bar)

Circuit diagram:

Hydraulic control, pilot pressure related, with constant pressure control HD1D, HD2D

Sizes 28...200

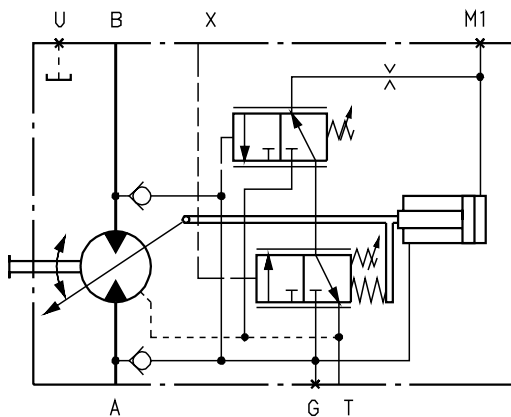

Sizes 250...1000

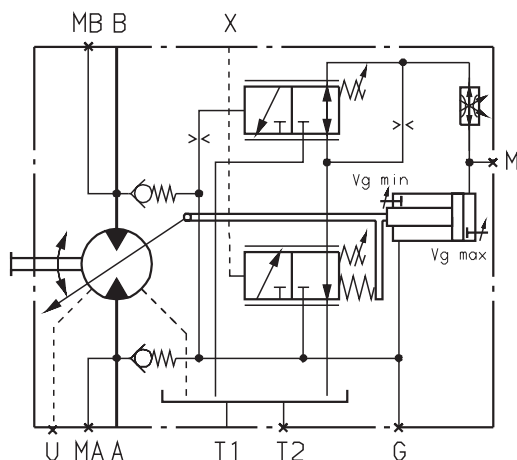

Variation: Remote constant pressure control (HD.G)

The remote pressure control controls the motor when reaching the set pressure command signal continuously until it reaches the max. displacement $V_{g \max}$. A pressure relief valve (not supplied), which is separate to the motor, is responsible for the control of the internal pressure cut-off valve. As long as the pressure command signal has not been obtained, the valve is, in addition to the spring force, pressurised from both sides, and is held closed. The pressure command signal is between 1160 and 5100 psi (80 bar and 350 bar). On reaching the pressure command signal at the separate pressure relief valve, this opens, whereby the pressure on the spring side is allowed to flow to tank. The internal pilot valve operates and the motor swivels to maximum displacement $V_{g \max}$. The pressure difference at the pilot valve is set as standard to 365 psi (25 bar). We recommend the following as a separate pressure relief valve:

DBD 6 (hydraulic) to RA 25402

The max. line length should not exceed 6 ft (2 m).

Circuit diagram:

Hydraulic control, pilot pressure related, with remote constant pressure control HD1G, HD2G

Sizes 250...1000

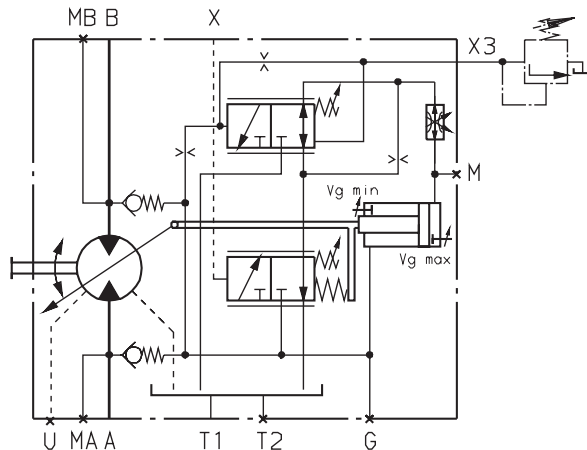

Unit dimensions HD1D, HD2D
Sizes 28...200

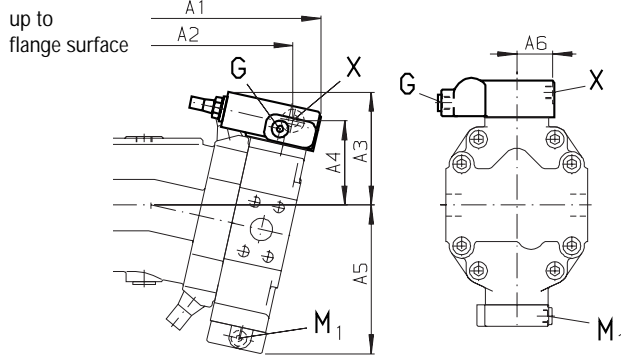

Size	A1	A2	A3	A4	A5	A6	port X
A6VM 28	8.43	7.44	4.69	3.43	5.35	1.40	M14x1,5
	(214)	(189)	(119)	(87)	(136)	(35,5)	
140	12.72	11.42	5.55	4.25	7.68	1.59	M14x1,5
	(323)	(290)	(141)	(108)	(195)	(40,5)	
AA6VM 55	10.43	9.45	4.72	3.50	5.94	1.40	9/16-18 UNF-2B
	(265)	(240)	(120)	(89)	(151)	(35,5)	
80	11.54	10.55	4.96	3.74	6.57	1.40	9/16-18 UNF-2B
	(293)	(268)	(126)	(95)	(167)	(35,5)	
107	12.72	11.42	5.24	3.98	6.89	1.59	9/16-18 UNF-2B
	(323)	(290)	(133)	(101)	(175)	(40,5)	
160	14.21	12.95	5.55	4.25	7.76	1.59	9/16-18 UNF-2B
	(361)	(329)	(141)	(108)	(197)	(40,5)	
200	14.88	13.58	5.71	4.41	8.23	1.59	9/16-18 UNF-2B
	(378)	(345)	(145)	(112)	(209)	(40,5)	

Unit dimensions HD1D, HD2D, HD1G, HD2G
Sizes 250...1000

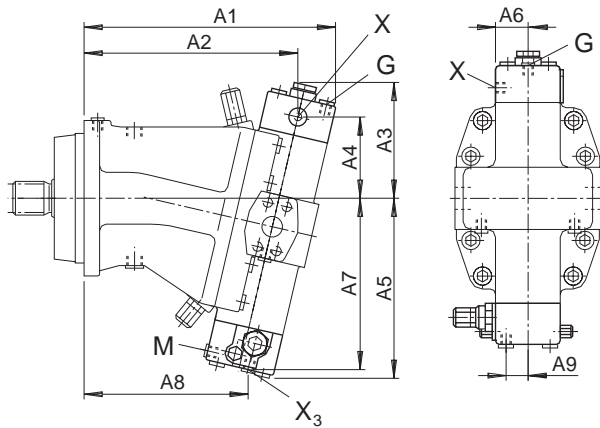

Size	A1	A2	A3	A4	A5	A6	A7	A8	A9	ports X, X ₃
AA6VM 250	16.81	14.53	7.40	4.84	10.71	1.91	10.08	12.52	1.38	9/16-18 UNF-2B
	(427)	(369)	(188)	(123)	(272)	(48,5)	(256)	(318)	(35)	
A6VM 355	17.01	14.41	7.99	5.39	11.34	2.13	10.67	11.30	1.30	M14x1,5
	(432)	(366)	(203)	(137)	(288)	(54)	(271)	(287)	(33)	
500	19.29	16.42	8.46	5.83	12.05	2.42	11.30	12.36	0.91	M14x1,5
	(490)	(417)	(215)	(148)	(306)	(61,5)	(287)	(314)	(23)	
1000										

Pilot pressure port X₃: open at HD.G, plugged at HD.D

HZ Hydraulic Two-Position Control

The hydraulic two-position control allows the displacement to be set to $V_{g\min}$ or $V_{g\max}$ by applying or venting pilot pressure at port X.

Standard version:

- start of control at $V_{g\max}$ (max. torque, min. speed)
- end of control at $V_{g\min}$ (min. torque, max. perm. speed)

Circuit diagram: Hydraulic two-position control HZ3
Sizes 55, 80, 107

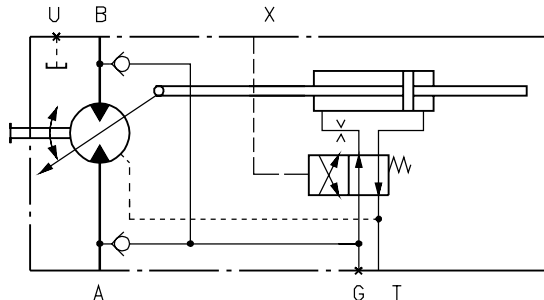

Unit dimensions HZ3

Sizes 55, 80, 107

Unit dimensions of control HZ (sizes 250...1000) and HZ1 (sizes 28, 140, 160, 200) see pages 22-32

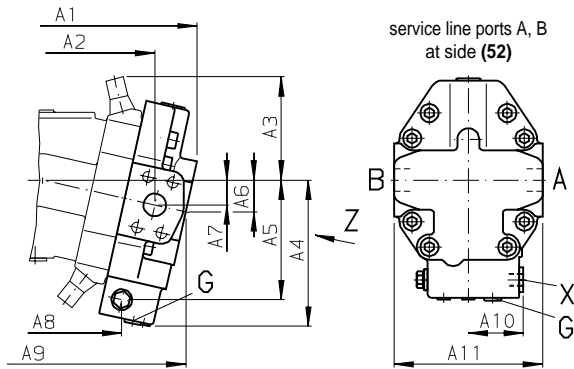

View Z service line ports A, B at rear end (51)

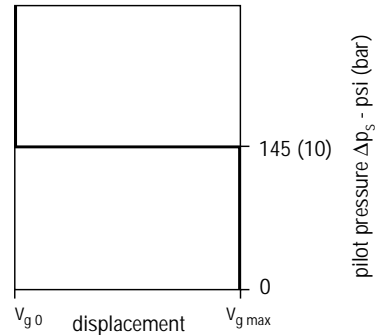
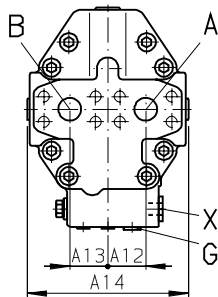

Circuit diagram: Hydraulic two-position control HZ1
Sizes 28, 140, 160, 200

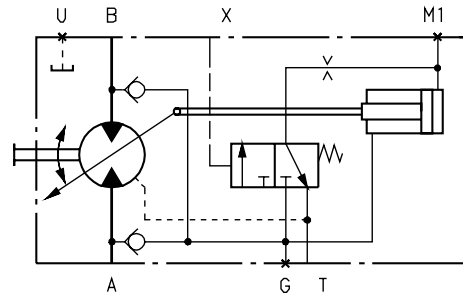

Circuit diagram: Hydraulic two-position control HZ
Sizes 250...1000

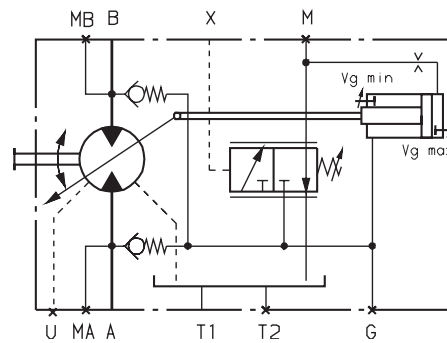

Size	A1	A2	A3	A4	A5	A6	A7	A8	A9	A10	A11	A12	A13	A14
AA6VM 55	9.88	8.15	3.94	5.75	4.61	1.22	0.94	6.89	9.41	2.40	5.98	1.48	1.48	6.30
	(251)	(207)	(100)	(146)	(117)	(31)	(24)	(175)	(239)	(61)	(152)	(37,5)	(37,5)	(160)
80	10.98	9.13	4.49	6.34	5.20	1.38	1.06	7.72	10.47	2.40	6.46	1.65	1.65	6.77
	(279)	(232)	(114)	(161)	(132)	(35)	(27)	(196)	(266)	(61)	(164)	(42)	(42)	(172)
107	11.89	9.92	4.80	6.81	5.63	1.50	1.18	8.43	11.34	2.40	7.09	1.65	1.65	7.40
	(302)	(252)	(122)	(173)	(143)	(38)	(30)	(214)	(288)	(61)	(180)	(42)	(42)	(188)
Size	Service line ports A, B ¹⁾						Pilot pressure port X							
AA6VM 55	SAE 3/4"; threads 2/8-16 UNC-2B						9/16-18 UNF-2B							
80	SAE 1"; threads 7/16-14 UNC-2B						9/16-18 UNF-2B							
107	SAE 1"; threads 7/16-14 UNC-2B						9/16-18 UNF-2B							

1) 6000 psi (420 bar) high pressure series

Variable Displacement Motor AA6VM (A6VM)

EP Electrical Control with Proportional Solenoid

The electrical control with proportional solenoid or proportional valve (sizes 250...1000) allows infinite variation of the motor displacement in relation to an electrical signal.

The control function is proportional to the electrical control current applied.

Sizes 28...200

	control voltage (DC)	control current start of control ($V_{g\ max}$)	control current end of control ($V_{g\ min} = 0$)
EP1	12 V	400 mA	1200 mA
EP2	24 V	200 mA	600 mA

Sizes 250...1000

	control voltage (DC)	control current start of control ($V_{g\ max}$)	control current end of control ($V_{g\ min} = 0,2 V_{g\ max}$)
EP1	12 V	900 mA	1400 mA
EP2	24 V	450 mA	700 mA

Pilot pressure p...435 psi, max. 1450 psi (30 bar, max. 100 bar)

Circuit diagram:

Electrical control with proportional solenoid EP1, EP2 Sizes 28...200

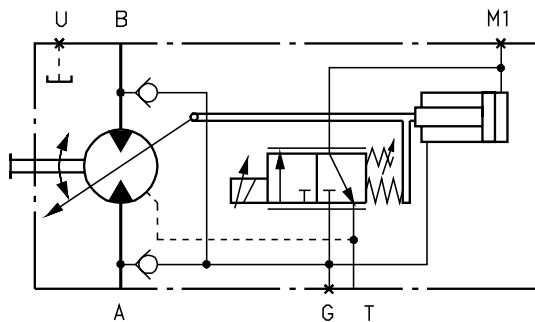

Circuit diagram:

Electrical control with proportional solenoid EP1, EP2 Sizes 250...1000

proportional valve DRE4K (see RA 29181)

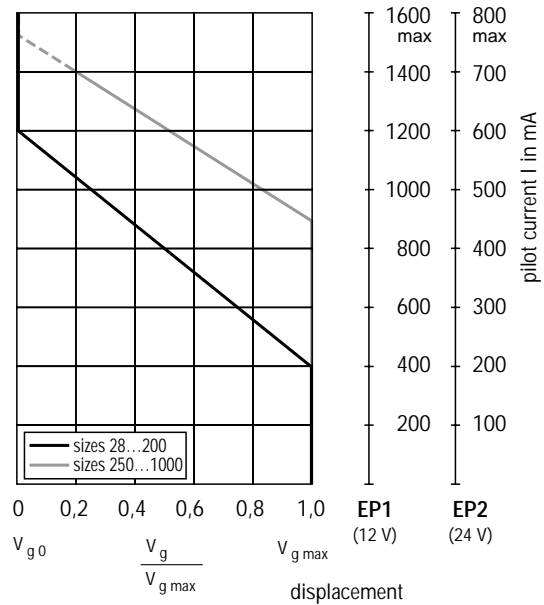
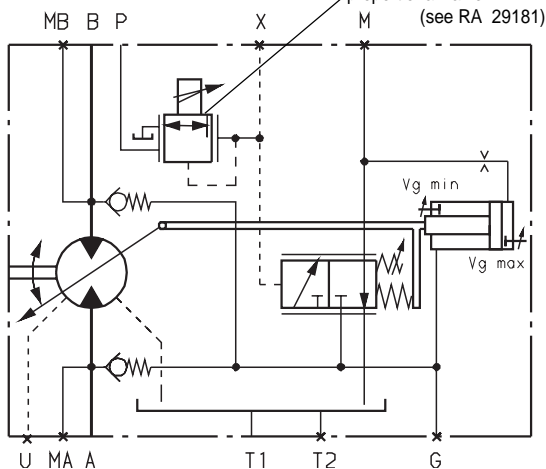

Standard version:

- start of control at $V_{g\ max}$ (max. torque, min. speed)
- end of control at $V_{g\ min}$ (min. torque, max. perm. speed)

Adjustment of the control speed or limiting of the displacement (limiting of swivel) range by electrical means is possible using the following control devices:

- Proportional amplifier PV _____ see RA 95023
- Chopper amplifier CV _____ see RA 95029
- Electrical amplifier 2014/15 _____ see RA 95027
- Electrical amplifier VT 2000, series 5 _____ see RA 29904

Variable Displacement Motor AA6VM (A6VM)

Variation: Direct constant pressure control (EP.D)

The constant pressure control is superimposed on the EP function. Should system pressure rise as a result of the load torque or reduction of the motor swivel angle, when the setting of the constant pressure control is reached the motor is swivelled out to a higher angle.

As a result of the increased displacement and consequent pressure reduction, the control deviation is eliminated. By increasing the displacement the motor produces a higher torque at a constant pressure.

Setting range of constant pressure control valve:

Sizes 28...200 _____ 1160 - 5800 psi (80 - 400 bar)

Sizes 250...1000 _____ 1160 - 5100 psi (80 - 350 bar)

Circuit diagram:

Electrical control with proportional solenoid, with direct constant pressure control EP1D, EP2D

Sizes 28...200

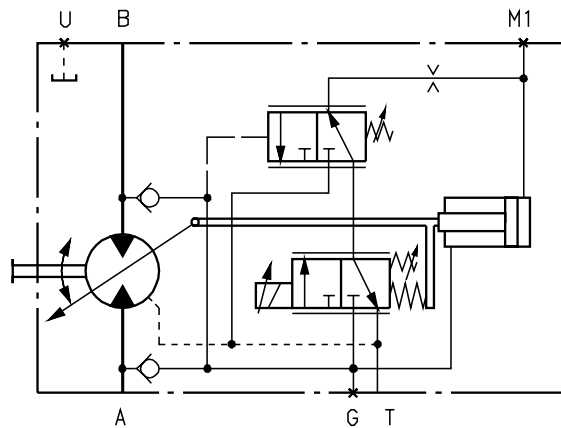

Sizes 250...1000

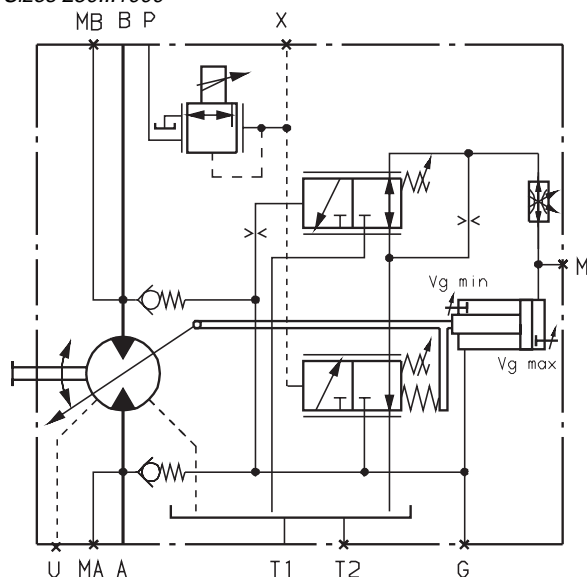

Variation: Remote constant pressure control (EP.G)

The remote pressure control controls the motor when reaching the set pressure command signal continuously until it reaches the max. displacement $V_{g \max}$. A pressure relief valve (not supplied), which is separate to the motor, is responsible for the control of the internal pressure cut-off valve. As long as the pressure command signal has not been obtained, the valve is, in addition to the spring force, pressurised from both sides, and is held closed. The pressure command signal is between 1160 psi and 5100 psi (80 bar and 350 bar). On reaching the pressure command signal at the separate pressure relief valve, this opens, whereby the pressure on the spring side is allowed to flow to tank. The internal pilot valve operates and the motor swivels to maximum displacement $V_{g \max}$. The pressure difference at the pilot valve is set as standard to 365 psi (25 bar). We recommend the following as a separate pressure relief valve:

DBD 6 (hydraulic) to RA 25402

The max. line length should not exceed 6 ft (2 m).

Circuit diagram:

Electrical control with proportional solenoid, with remote constant pressure control EP1G, EP2G

Sizes 250...1000

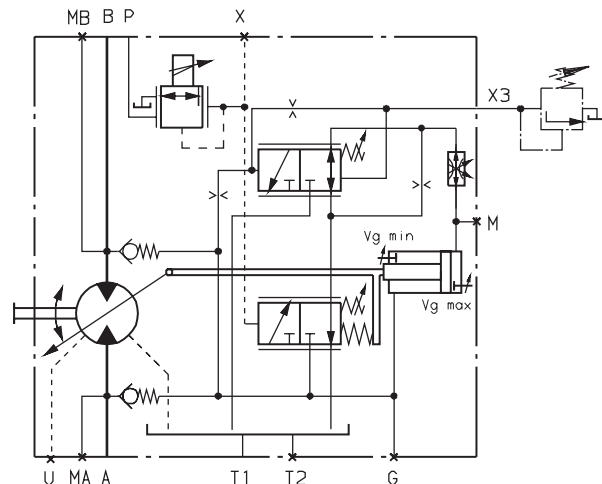

Unit dimensions EP1, EP2

Sizes 28...200

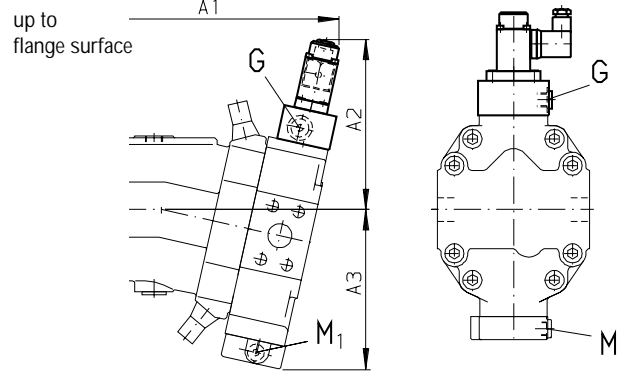

Size	A1	A2	A3
A6VM 28	8.43 (214)	6.54 (166)	5.35 (136)
140	12.68 (322)	7.36 (187)	7.68 (195)
AA6VM 55	10.43 (265)	6.57 (167)	5.94 (151)
80	11.54 (293)	6.81 (173)	6.57 (167)
107	12.72 (323)	7.05 (179)	6.89 (175)
160	14.21 (361)	7.36 (187)	7.76 (197)
200	14.84 (377)	7.52 (191)	8.23 (209)

Unit dimensions EP1D, EP2D

Sizes 28...200

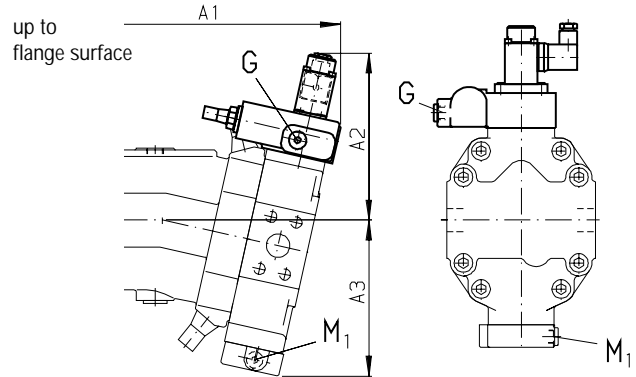

Size	A1	A2	A3
A6VM 28	8.43 (214)	6.54 (166)	5.35 (136)
140	12.68 (322)	7.36 (187)	7.68 (195)
AA6VM 55	10.43 (265)	6.57 (167)	5.94 (151)
80	11.54 (293)	6.81 (173)	6.57 (167)
107	12.72 (323)	7.05 (179)	6.89 (175)
160	14.21 (361)	7.36 (187)	7.76 (197)
200	14.84 (377)	7.52 (191)	8.23 (209)

Unit dimensions EP1, EP2

Sizes 250...1000

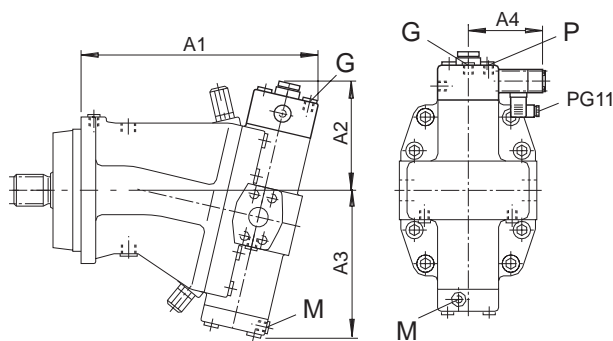

Size	A1	A2	A3	A4
AA6VM 250	16.81 (427)	7.40 (188)	10.71 (272)	4.88 (124)
A6VM 355	17.01 (432)	7.99 (203)	11.34 (288)	4.92 (125)
500	19.29 (490)	8.46 (215)	12.05 (306)	5.20 (132)
1000				

Pilot pressure port P: AA6VM 250 9/16-18 UNF-2B
A6VM 250...1000 M 14x1,5

Pilot pressure port X₃: AA6VM 250 9/16-18 UNF-2B
A6VM 250...1000 M 14x1,5
(open at EP.G, plugged at EP.D)

Unit dimensions EP1D, EP2D, EP1G, EP2G

Sizes 250...1000

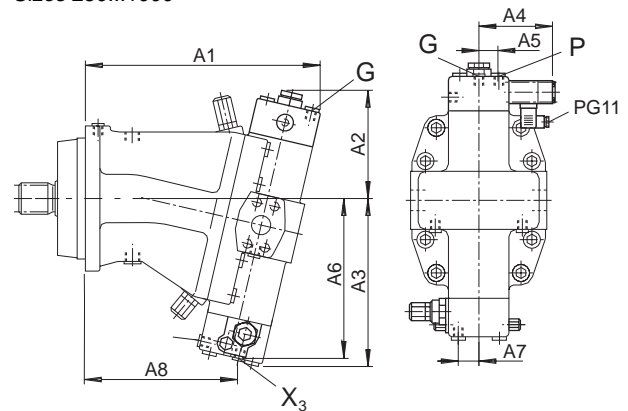

Size	A1	A2	A3	A4
AA6VM 250	16.81 (427)	7.40 (188)	10.71 (272)	4.88 (124)
A6VM 355	17.01 (432)	7.99 (203)	11.34 (288)	4.92 (125)
500	19.29 (490)	8.46 (215)	12.05 (306)	5.20 (132)
1000				

Size	A5	A6	A7	A8
AA6VM 250	1.42 (36)	10.08 (256)	1.38 (35)	12.17 (309)
A6VM 355	1.42 (36)	10.67 (271)	1.30 (33)	11.30 (287)
500	1.69 (43)	11.30 (287)	1.26 (32)	12.36 (314)
1000				

EZ Electrical Two-Position Control with Switching Solenoid

The electrical two-position control with switching solenoid allows the displacement to be set to $V_{g,max}$ or $V_{g,min}$ by energizing or de-energizing the solenoid.

Solenoid de-energized $\hat{=}$ motor set to $V_{g,max}$
Solenoid energized $\hat{=}$ motor set to $V_{g,min}$

EZ1, EZ3 switching solenoid 12 V DC, 26W (EZ1) 30W (EZ3)

EZ2, EZ4 switching solenoid 24 V DC, 26W (EZ2) 30W (EZ4)

Electrical two-position control EZ1, EZ2 Sizes 28, 140, 160, 200

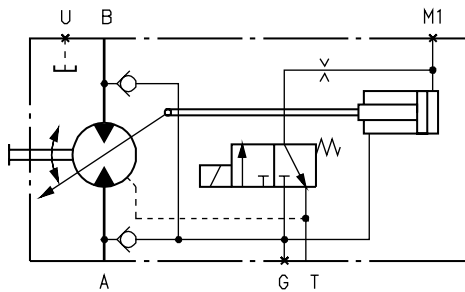

Electrical two-position control EZ3, EZ4 Sizes 55, 80, 107

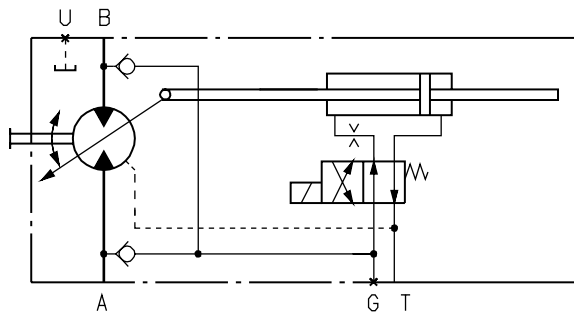

Electrical two-position control EZ1, EZ2 Sizes 250...1000

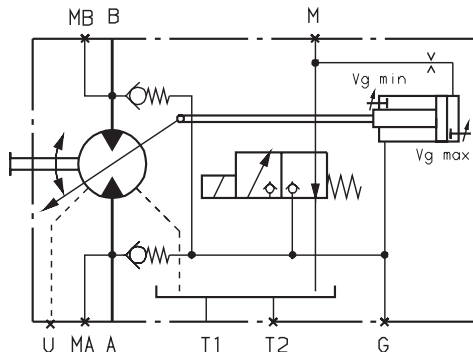

Unit dimensions EZ1, EZ2 Sizes 28, 140, 160, 200

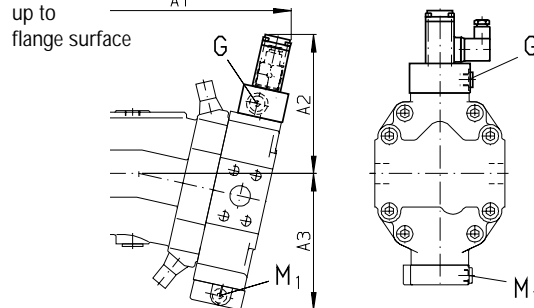

Size	A1	A2	A3
A6VM 28	8.50 (216)	6.42 (163)	5.35 (136)
140	12.64 (321)	7.24 (184)	7.68 (195)
AA6VM 160	14.17 (360)	7.24 (184)	7.76 (197)
200	14.80 (376)	7.40 (188)	8.23 (209)

Unit dimensions EZ1, EZ2 Sizes 55, 80, 107

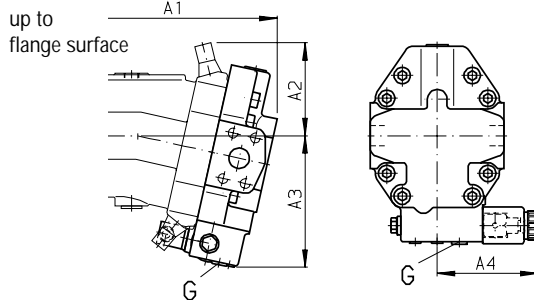

Size	A1	A2	A3	A4
AA6VM 55	9.88 (251)	3.94 (100)	5.75 (146)	4.88 (124)
80	10.98 (279)	4.49 (114)	6.34 (161)	4.88 (124)
107	11.89 (302)	4.80 (122)	6.81 (173)	4.88 (124)

(Additional dimensions of the port plate see page 11, HZ3-control)

Unit dimensions EZ1, EZ2 Sizes 250...1000

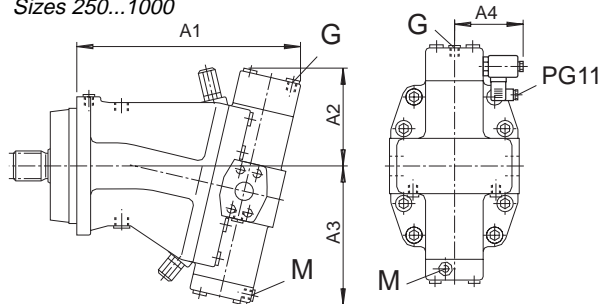

Size	A1	A2	A3	A4
AA6VM 250	16.81 (427)	6.73 (171)	9.76 (248)	4.92 (125)
A6VM 355	17.01 (432)	7.17 (182)	10.98 (279)	5.06 (128,5)
500	19.29 (490)	7.76 (197)	12.05 (306)	5.33 (135,5)
1000				

Variable Displacement Motor AA6VM (A6VM)

DA Hydraulic Control, Speed Related

The AA6VM (A6VM) variable motor with speed related hydraulic control is particularly suitable for use in hydrostatic transmissions in conjunction with variable pump AA4VG with DA control.

The swivel angle of the hydraulic motor is controlled by means of the pilot pressure determined by the input speed of the AA4VG variable pump and by the operating pressure.

An increase in the pump input speed and thus in the pilot pressure causes the motor, in relation to the existing operating pressure, to swivel towards a lower displacement volume (lower torque, higher speed).

If operating pressure should rise above the value set with the pressure control, the motor is then swivelled towards a higher displacement volume (higher torque, lower speed).

DA (sizes 250...1000) DA1, DA4 (sizes 28...200)

Hydraulic valve for travel direction

Through the control pressure X_1 or X_2 this valve is switched on/off dependent on the direction of rotation (travel direction)

direction of rotation	operating pressure in	switching solenoid a
clockwise	A	X_1
anti-clockwise	B	X_2

Circuit diagram:

Hydraulic control, speed related DA1, DA4
Sizes 28...200

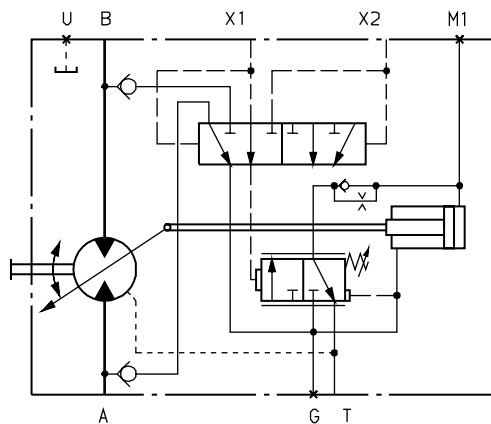

Circuit diagram:

Hydraulic control, speed related DA
Sizes 250...1000

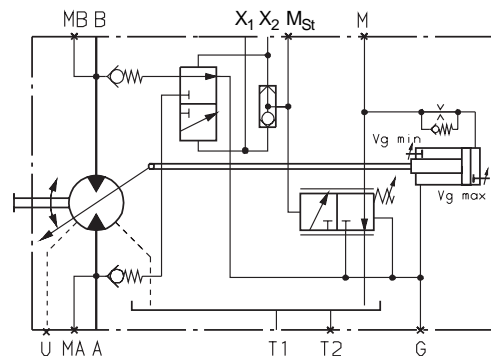

When designing a drive using DA control, note also the technical data of variable pump A4VG with DA control.

A computer program is available at Rexroth to help you with the design of your drive. Full details on request.

DA2, DA3, DA5, DA6 (sizes 28...200)

El. valve for travel direction + el. $V_{g\ max}$ -switching process

The electrical valve is operated by the pressure spring or switch solenoid (a) dependent on the rotational direction (travel direction).

Through connection of the electric current at the switch solenoid (b) override of the control is possible and the motor is switched to max. swivel angle (high torque, low speed) (el. $V_{g\ max}$ -switching process).

DA2, DA5	switching solenoid a, b 12 V DC; 1,6 A (min.)
DA3, DA6	switching solenoid a, b 24 V DC; 0,8 A (min.)

direction of rotation	operating pressure in	switching solenoid a
clockwise	A	energized
anti-clockwise	B	de-energized

Circuit diagram:

Hydraulic control, speed related DA2, DA3, DA5, DA6
Sizes 28...200

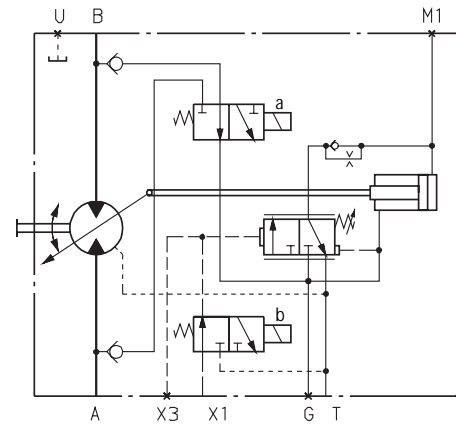

Variable Displacement Motor AA6VM (A6VM)

Before finalising your design, please request a certified drawing.
Dimensions in inches and millimeters ().

Unit dimensions DA1, DA4

Sizes 28...200

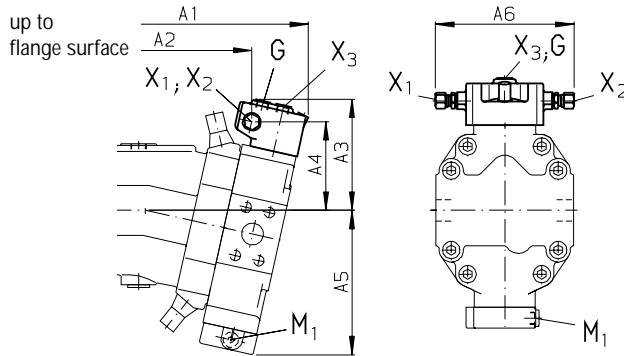

Size	A1	A2	A3	A4	A5	A6	ports X ₁ , X ₂
A6VM 28	8.50 (216)	5.98 (152)	4.72 (120)	3.66 (93)	5.35 (136)	6.30 (160)	locking GE-8LM
140	12.68 (322)	9.72 (247)	5.55 (141)	4.53 (115)	7.68 (195)	6.85 (174)	locking GE-8LM
AA6VM 55	10.47 (266)	7.99 (203)	4.80 (122)	3.70 (94)	5.94 (151)	6.30 (160)	7/16-20 UNF-2B
80	11.61 (295)	9.09 (231)	5.00 (127)	3.94 (100)	6.57 (167)	6.30 (160)	7/16-20 UNF-2B
107	12.72 (323)	9.76 (248)	5.28 (134)	4.21 (107)	6.89 (175)	6.85 (174)	7/16-20 UNF-2B
160	14.21 (361)	11.26 (286)	5.55 (141)	4.53 (115)	7.76 (197)	6.85 (174)	7/16-20 UNF-2B
200	14.88 (378)	11.93 (303)	5.75 (146)	4.69 (119)	8.23 (209)	6.85 (174)	7/16-20 UNF-2B

Unit dimensions DA2, DA3, DA5, DA6

Sizes 28...200

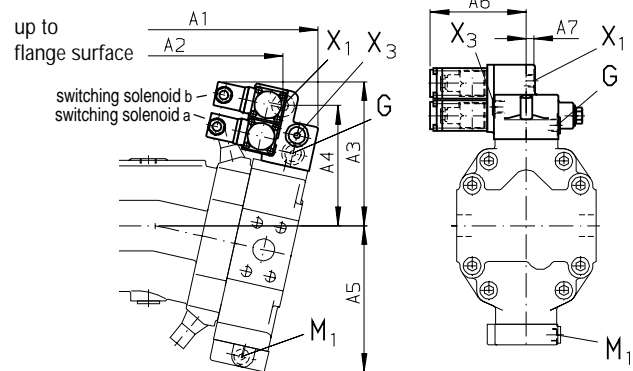

Size	A1	A2	A3	A4	A5	A6	A7	port X ₁
A6VM 28	8.58 (218)	6.89 (175)	6.22 (158)	5.12 (130)	5.35 (136)	4.33 (110)	0.33 (8,5)	M14x1,5
140	12.72 (323)	10.63 (270)	7.13 (181)	6.06 (154)	7.68 (195)	4.41 (112)	0.33 (8,5)	M14x1,5
AA6VM 55	10.59 (269)	8.90 (226)	6.26 (159)	5.20 (132)	5.94 (151)	4.33 (110)	0.33 (8,5)	9/16-18 UNF-2B
80	11.61 (295)	10.00 (254)	6.38 (162)	5.43 (138)	6.57 (167)	4.33 (110)	0.33 (8,5)	9/16-18 UNF-2B
107	12.76 (324)	10.67 (271)	6.81 (173)	5.75 (146)	6.89 (175)	4.41 (112)	0.33 (8,5)	9/16-18 UNF-2B
160	14.25 (362)	12.17 (309)	7.13 (181)	6.02 (153)	7.76 (197)	4.41 (112)	0.33 (8,5)	9/16-18 UNF-2B
200	14.92 (379)	12.83 (326)	7.28 (185)	6.22 (158)	8.23 (209)	4.41 (112)	0.33 (8,5)	9/16-18 UNF-2B

X₁: pilot pressure port

Unit dimensions DA

Sizes 250...1000

Note: different position of the ports G and M_{St} for size 250 and sizes 355, 500

Size 250

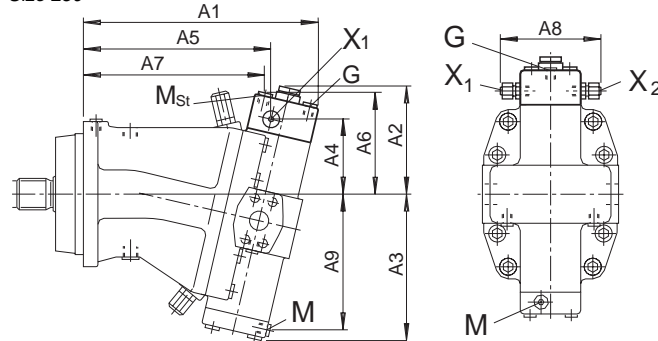

Sizes 355, 500

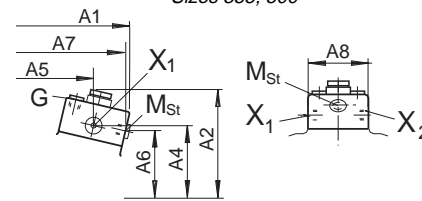

Size	A1	A2	A3	A4	A5	A6	A7	A8	A9	ports X ₁ , X ₃
AA6VM 250	16.81 (427)	7.40 (188) ¹⁾	9.76 (248)	4.96 (126)	13.74 (349)	6.34 (161)	13.31 (338)		8.94 (227)	9/16-18 UNF-2B
A6VM 355	17.01 (432)	7.99 (203) ¹⁾	10.98 (279)	5.51 (140)	12.87 (327)	4.84 (123)	16.61 (422)	4.25 (108)	10.12 (257)	M14x1,5
500	19.29 (490)	8.46 (215) ¹⁾	12.05 (306)	5.94 (151)	16.65 (423)	5.39 (137)	18.94 (481)	4.84 (123)	11.18 (284)	M14x1,5
1000										

¹⁾ max.

HA Automatic Control, High Pressure Related

With the automatic, high pressure related control, setting of the displacement is effected automatically as a function of the operating pressure.

This control device measures the operating pressure at A or B internally (no pilot line required) and swivels from $V_{g \min}$ to $V_{g \max}$ once the pressure setting of the control is reached.

Standard version:

start of control at $V_{g \min}$ (no torque, max. perm. speed)

end of control at $V_{g \max}$ (max. torque, min. speed)

HA1

Version with virtually no pressure increase from start of control to end of control.

Pressure increase:

sizes 28...200 ($V_{g \min} = 0$ to $V_{g \max}$) $\leq \Delta p$ 145 psi (10 bar)

sizes 250...1000 ($V_{g \min} = 0,2 V_{g \max}$ to $V_{g \max}$) $\leq \Delta p$ 145 psi (10 bar)

Start of control, setting range :

sizes 28...200 1160 - 5100 psi (80 - 350 bar)

sizes 250...1000 1160 - 4900 psi (80 - 340 bar)

(state required setting in clear text when ordering)

Circuit diagram:

Automatic control, high pressure related HA1

Sizes 28...200

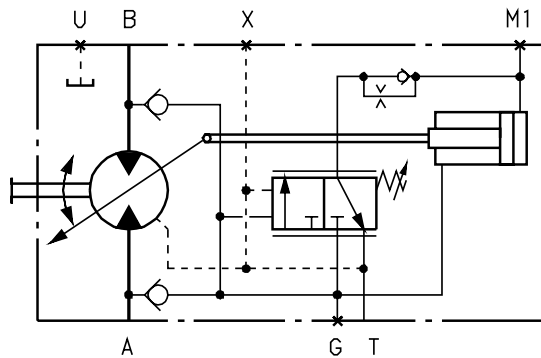

Sizes 250...1000

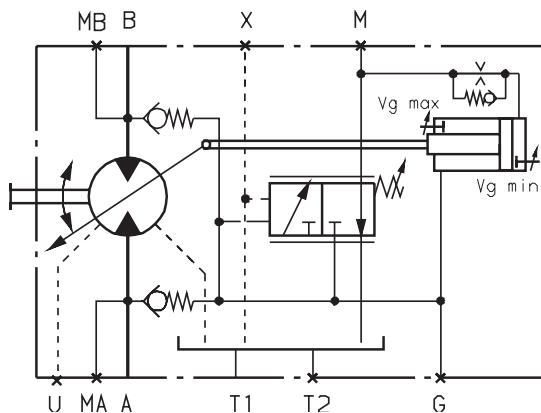

HA1

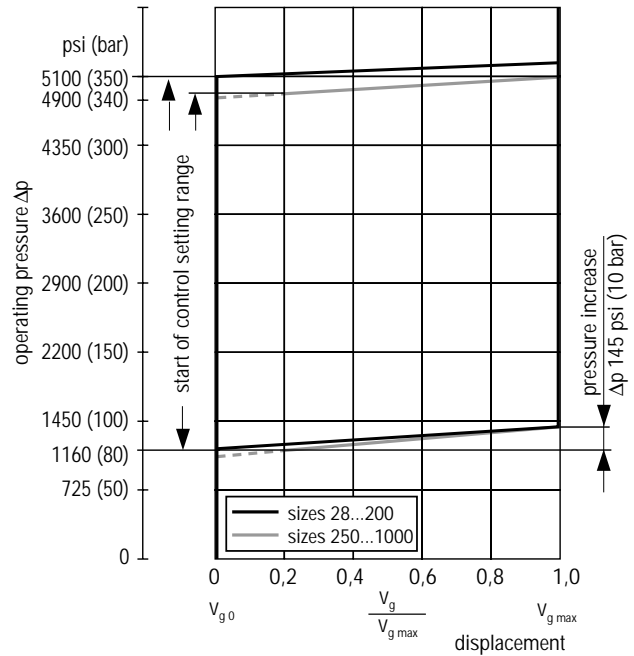

Variable Displacement Motor AA6VM (A6VM)

HA2

Version with pressure increase from start of control to end of control.

Pressure increase:

sizes 28...200 ($V_{g\ min} = 0$ to $V_{g\ max}$) $\Delta p \leq 1450$ psi (100 bar)

sizes 250...1000 ($V_{g\ min} = 0,2 V_{g\ max}$ to $V_{g\ max}$) $\Delta p \leq 1450$ psi (100 bar)

Start of control, setting range:

sizes 28...200 1160 - 5100 psi (80 - 350 bar)

sizes 250...1000 1160 - 3600 psi (80 - 250 bar)

(state required setting in clear text when ordering)

Circuit diagram:

Automatic control, high pressure related HA2

Sizes 28...200

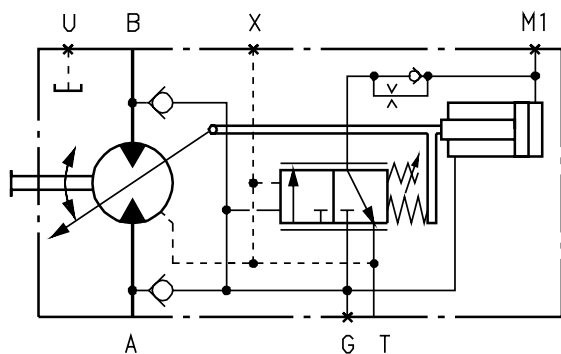

Sizes 250...1000

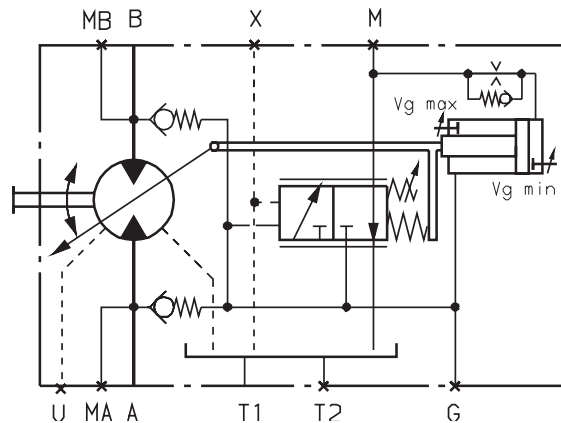

HA2

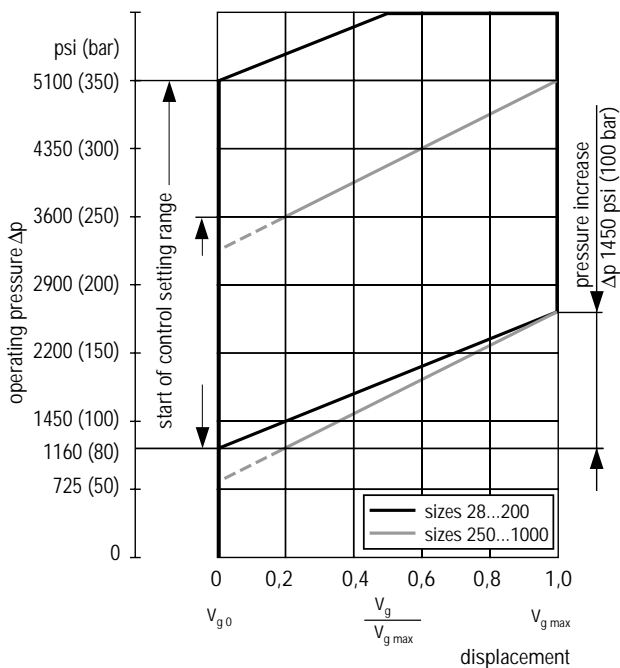

Variation: Hydraulic override of pressure setting (HA.T)

On versions HA1 and HA2 the pressure setting (start of control) can be influenced by applying a pilot pressure at port X.

The pressure setting is reduced by:

sizes 28...200 17 psi (17 bar)
 sizes 250...1000 8 psi (8 bar)
 per 1 psi (1 bar) pilot pressure.

(i.e. - Pilot pressure to high pressure ratio: 1:17)

Example (sizes 28...200):

pressure setting	4350 psi (300 bar)	4350 psi (300 bar)
pilot pressure at port X	0 psi (0 bar)	145 psi (10 bar)
start of control	4350 psi (300 bar)	1885 psi (130 bar)

If the override is only required to set the max displacement (motor swivel to $V_{g\ max}$), a pilot pressure of up to 1450 psi (100 bar) max. is permissible.

(Circuit diagram and unit dimensions see control HA1, HA2, port X open, no connection from X to T)

Variable Displacement Motor AA6VM (A6VM)

**Variation: Electrical override of pressure setting
(HA.U1, HA.U2)**

On versions HA1 and HA2 the high pressure related control can be overridden by means of an electrical signal to a switching solenoid. The override causes the motor to swivel to its maximum angle.

Switching solenoid de-energised $\hat{=}$ no override
 Switching solenoid energised $\hat{=}$ motor set to $V_{g,max}$

HA.U1	switching solenoid 12 V DC, 1,6 A (min.)
HA.U2	switching solenoid 24 V DC, 0,8 A (min.)

Start of control adjustable between 1160 psi and 4350 psi (80 and 300 bar)
 (state required setting in clear text when ordering)

Circuit diagram:

Automatic control, with electrical override HA1U1, HA1U2
 Sizes 28...200

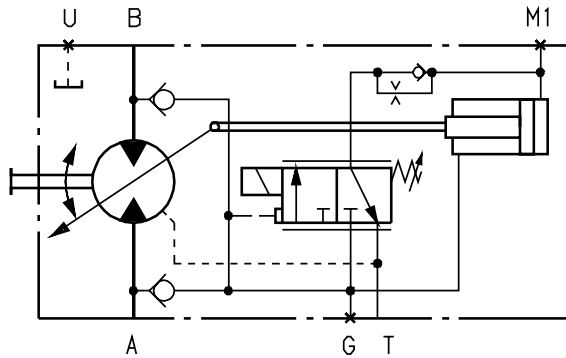

HA2U1, HA2U2 Sizes 28...200

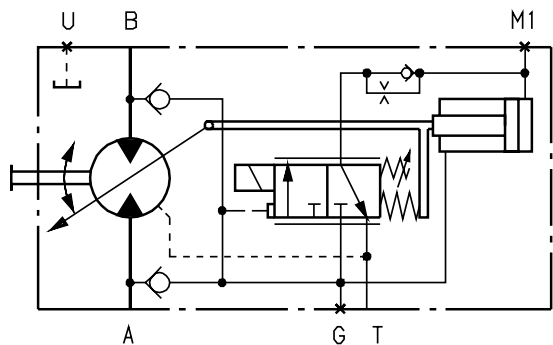

**Variation: Electrical override of pressure setting,
with electrical valve for travel direction
(HA.R1, HA.R2)**

On version HA1 and HA2 the high pressure related control can be overridden by means of an electrical signal to the switching solenoid b. The override causes the variable motor to swivel to its maximum angle.

Switching solenoid b de-energised $\hat{=}$ no override
 Switching solenoid b energized $\hat{=}$ motor set to $V_{g,max}$

The travel directional valve ensures that also at a change of the high pressure side (for instance travel drive at down hill operation) always the preselected pressure side of the hydraulic motor regulates the swivel angle.

An undesired swivel of the variable motor to bigger stroke volume can be avoided.

In depending of the direction (travel direction) the travel directional valve is actuated by the pressure spring or the switching solenoid a.

direction of rotation	operating pressure in	switching solenoid a
clockwise	A	energized
counter-clockwise	B	de-energized

HA.R1	switching solenoid a, b 12 V DC; 1,6 A (min.)
HA.R2	switching solenoid a, b 24 V DC; 0,8 A (min.)

Circuit diagram:

**Automatic control, with electrical override and
electrical valve for travel direction**
HA1R1, HA1R2 Sizes 28...200

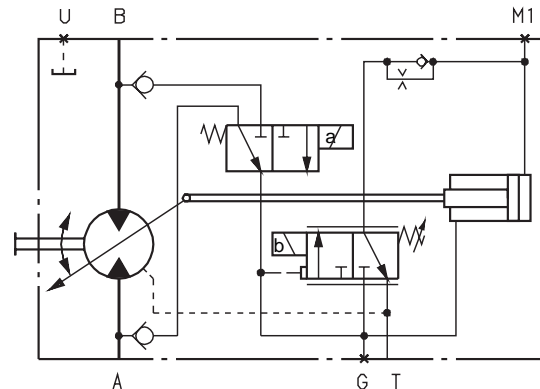

HA2R1, HA2R2 Sizes 28...200

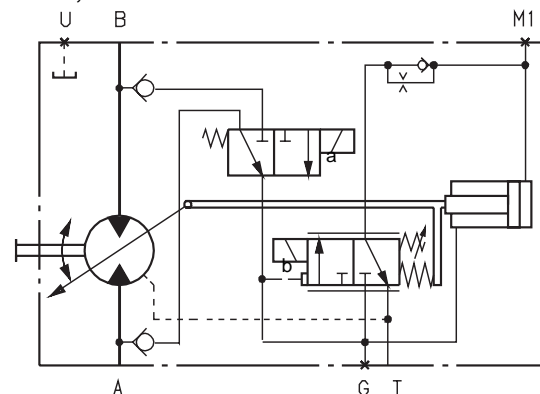

Variable Displacement Motor AA6VM (A6VM)

Before finalising your design, please request a certified drawing.
Dimensions in inches and millimeters ().

Unit dimensions HA1, HA2, HA1T, HA2T
Sizes 28...200

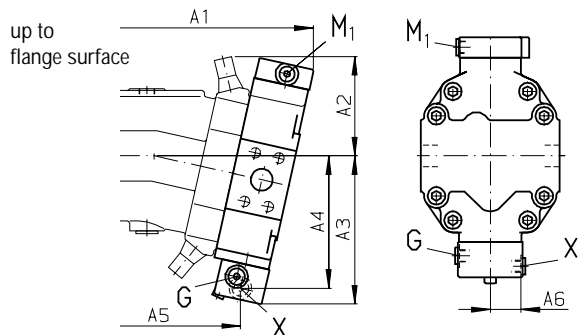

Size	A1	A2	A3	A4	A5	A6
A6VM 28	8.23 (209)	3.82 (97)	5.94 (151)	5.24 (133)	5.28 (134)	1.36 (34,5)
140	12.44 (316)	5.20 (132)	7.80 (198)	7.01 (178)	8.86 (225)	1.59 (40,5)
AA6VM 55	10.28 (261)	4.09 (104)	6.26 (159)	5.59 (142)	7.20 (183)	1.31 (33,4)
80	11.50 (292)	4.49 (114)	6.73 (171)	5.98 (152)	8.15 (207)	1.36 (34,5)
107	12.68 (322)	4.80 (122)	7.20 (183)	6.46 (164)	9.09 (231)	1.59 (40,5)
160	13.98 (355)	5.39 (137)	7.87 (200)	7.13 (181)	10.39 (264)	1.59 (40,5)
200	14.61 (371)	5.63 (143)	8.23 (209)	7.48 (190)	10.91 (277)	1.59 (40,5)

port X: A6VM 28/140 _____ M14x1,5
AA6VM 55...200 _____ 9/16-18 UNF-2B
(plugged, open for design HA.T)

Unit dimensions HA1, HA2, HA1T, HA2T
Sizes 250...1000

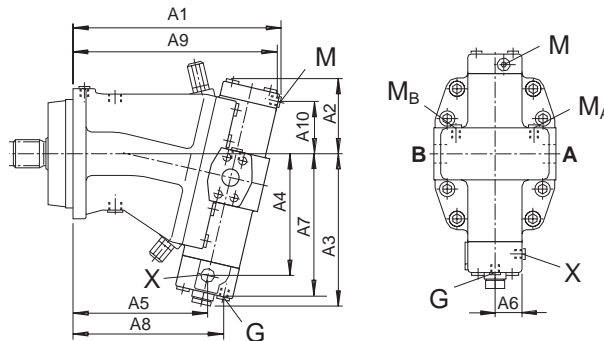

Size	A1	A2	A3	A4	A5	A6	A7	A8	A9	A10
AA6VM 250	16.77 (426)	6.34 (161)	10.83 (275)	8.27 (210)	11.42 (290)	1.91 (48,5)	9.76 (248)	12.60 (320)	16.50 (419)	4.57 (116)
A6VM 355	17.01 (432)	7.13 (181)	11.81 (300)	9.21 (234)	10.98 (279)	2.13 (54)	10.83 (275)	12.40 (315)	16.73 (425)	5.20 (132)
500	19.25 (489)	7.72 (196)	12.80 (325)	10.16 (258)	12.68 (322)	2.42 (61,5)	11.81 (300)	14.13 (359)	19.02 (483)	5.67 (144)
1000										

port X: AA6VM 250 _____ 9/16-18 UNF-2B
A6VM 355...1000 _____ M14x1,5
(plugged, open for design HA.T)

Unit dimensions HA1U1, HA1U2, HA2U1, HA2U2
Sizes 28...200

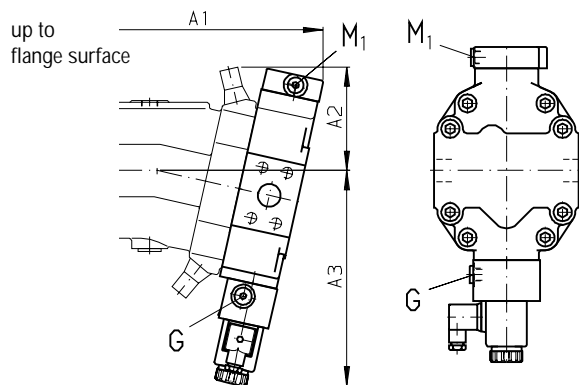

Size	A1	A2	A3
A6VM 28	8.23 (209)	3.82 (97)	8.50 (216)
140	12.44 (316)	5.20 (132)	10.35 (263)
AA6VM 55	10.28 (261)	4.09 (104)	8.82 (224)
80	11.50 (292)	4.49 (114)	9.37 (238)
107	12.36 (314)	4.80 (122)	9.80 (249)
160	13.98 (355)	5.39 (137)	10.47 (266)
200	14.61 (371)	5.63 (143)	10.83 (275)

Unit dimensions HA1R1, HA1R2, HA2R1, HA2R2
Sizes 28...200

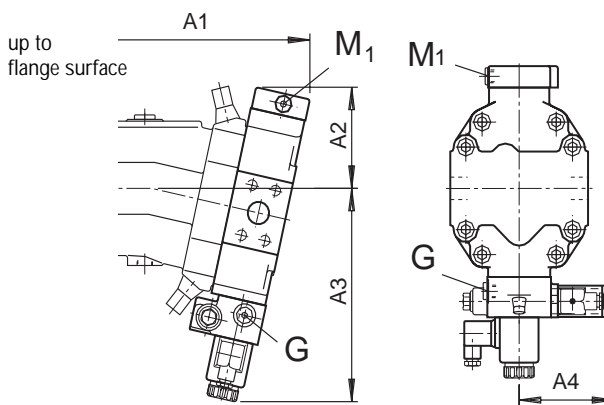

Size	A1	A2	A3	A4
A6VM 28	8.23 (209)	3.82 (97)	8.50 (216)	4.33 (110)
140	12.44 (316)	5.20 (132)	10.35 (263)	4.41 (112)
AA6VM 55	10.28 (261)	4.09 (104)	8.82 (224)	4.33 (110)
80	11.50 (292)	4.49 (114)	9.37 (238)	4.33 (110)
107	12.36 (314)	4.80 (122)	9.80 (249)	4.41 (112)
160	13.98 (355)	5.39 (137)	10.47 (266)	4.41 (112)
200	14.61 (371)	5.63 (143)	10.83 (275)	4.41 (112)

Unit Dimensions, Size 28 (ISO-Version)

Hydraulic control, pilot pressure related HD1, HD2
Hydraulic two-position control HZ1

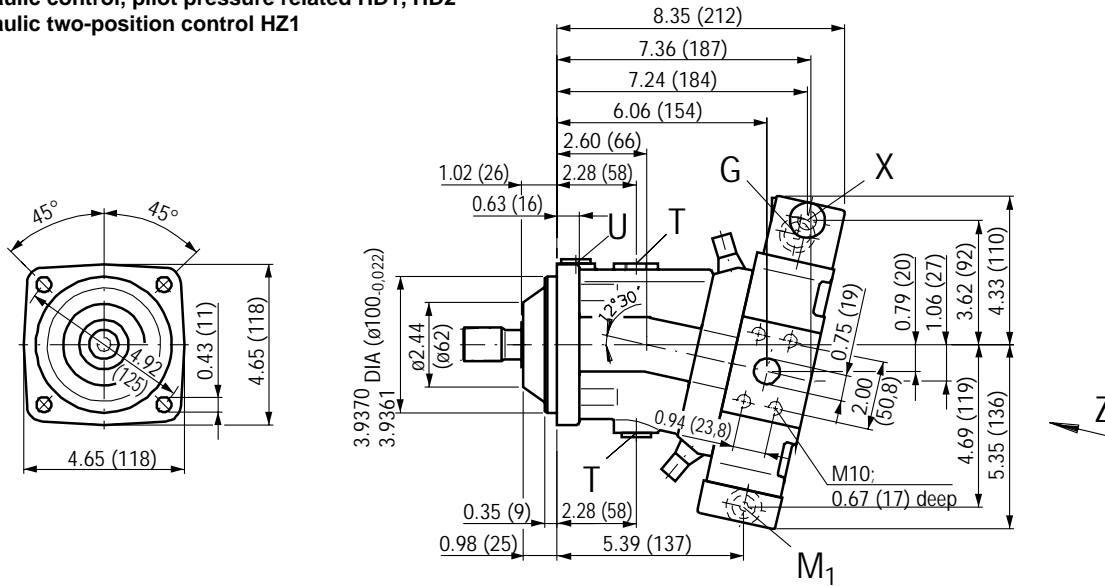

Service line ports A/B at rear end (01)
View Z

Service line ports A/B on (opposite) sides (02)
View Z

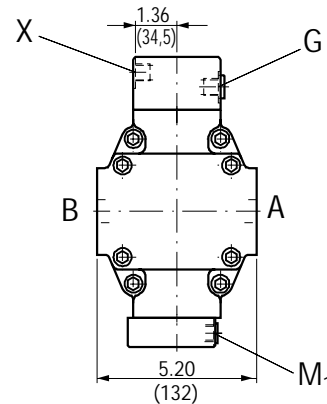
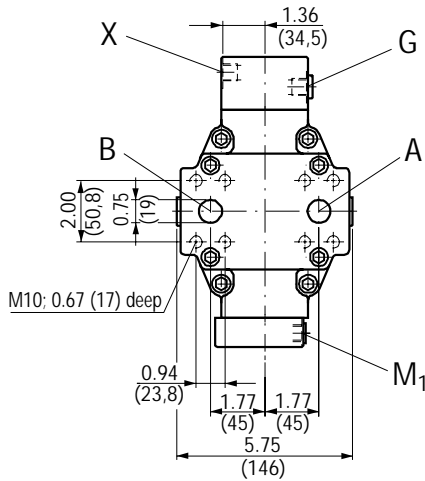

Shaft ends

A
Splined shaft, DIN 5480
W 30x2x30x14x9g

Z
Splined shaft, DIN 5480
W 25x1,25x30x18x9g

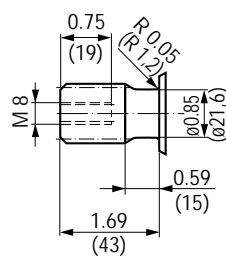
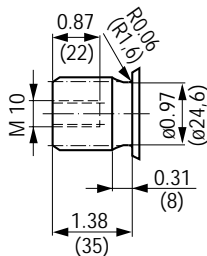

Connections

A, B	Service line ports	SAE 3/4"
	6000 psi (420 bar) high pressure series	
G	Port for synchronous control of a number of units and for remote control pressure (plugged)	M14x1,5
X	Pilot pressure port	M14x1,5
T	Case drain ports	M18x1,5
U	Flushing port (plugged)	M16x1,5
M ₁	Test port for control pressure (plugged)	M14x1,5

Unit Dimensions, Size 55 (SAE Version)

Hydraulic control, pilot pressure related HD1, HD2

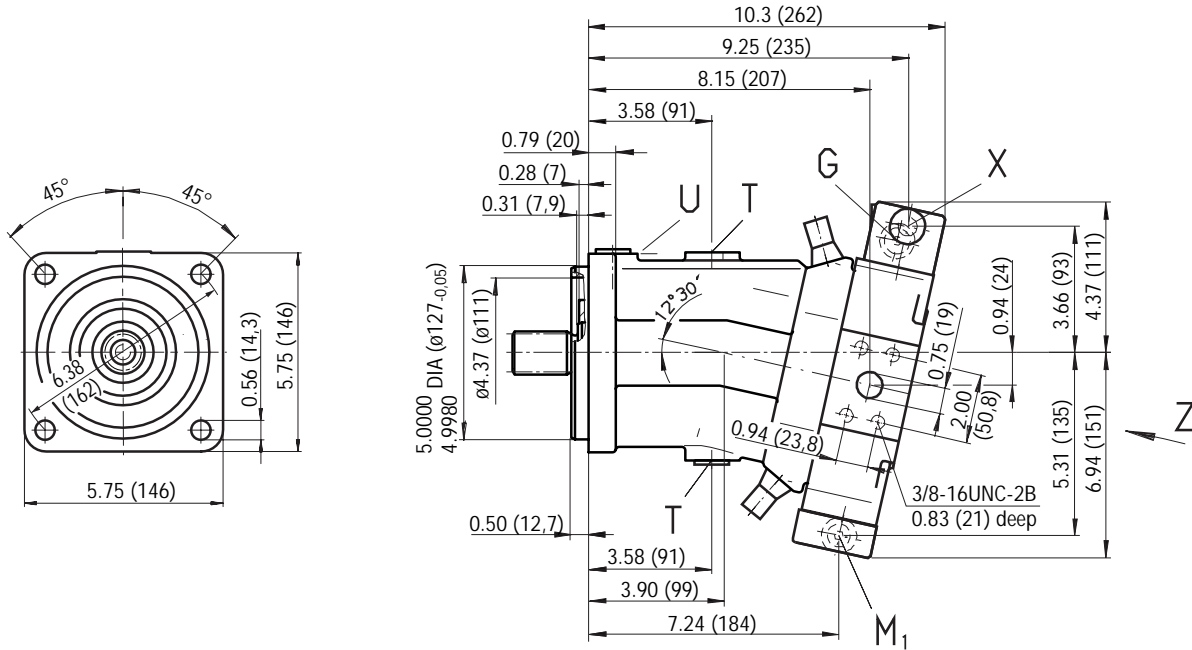

Service line ports A/B at rear end (51)

View Z

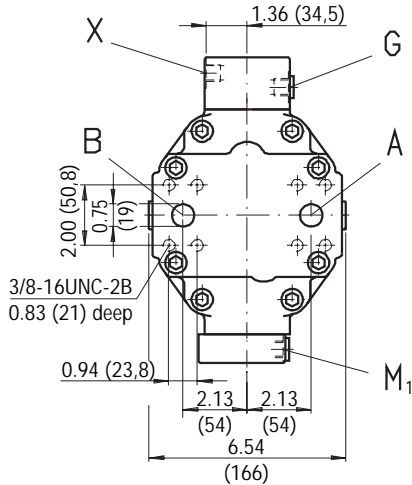

Service line ports A/B on (opposite) sides (52)

View Z

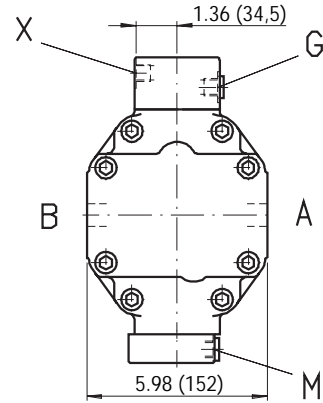

Shaft end

S

Splined shaft, SAE 1 1/4"
14 T, 12/24 DP, Tolerance class 5
ANSI B92.1a-1976

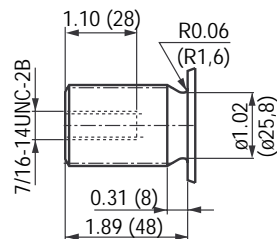

Connections

A,B	Service line ports	SAE 3/4"
	6000 psi (420 bar) high pressure series	
G	Port for synchronous control of a number of units and for remote control pressure (plugged)	SAE 6, 9/16-18UNF-2B
X	Pilot pressure port	SAE 6, 9/16-18UNF-2B
T	Case drain ports	SAE 12, 1 1/16-12UNF-2B
U	Flushing port (plugged)	SAE 10, 7/8-14UNF-2B
M ₁	Test port for control pressure (plugged)	SAE 6, 9/16-18UNF-2B

Unit Dimensions, Size 80 (SAE Version)

Hydraulic control, pilot pressure related HD1, HD2

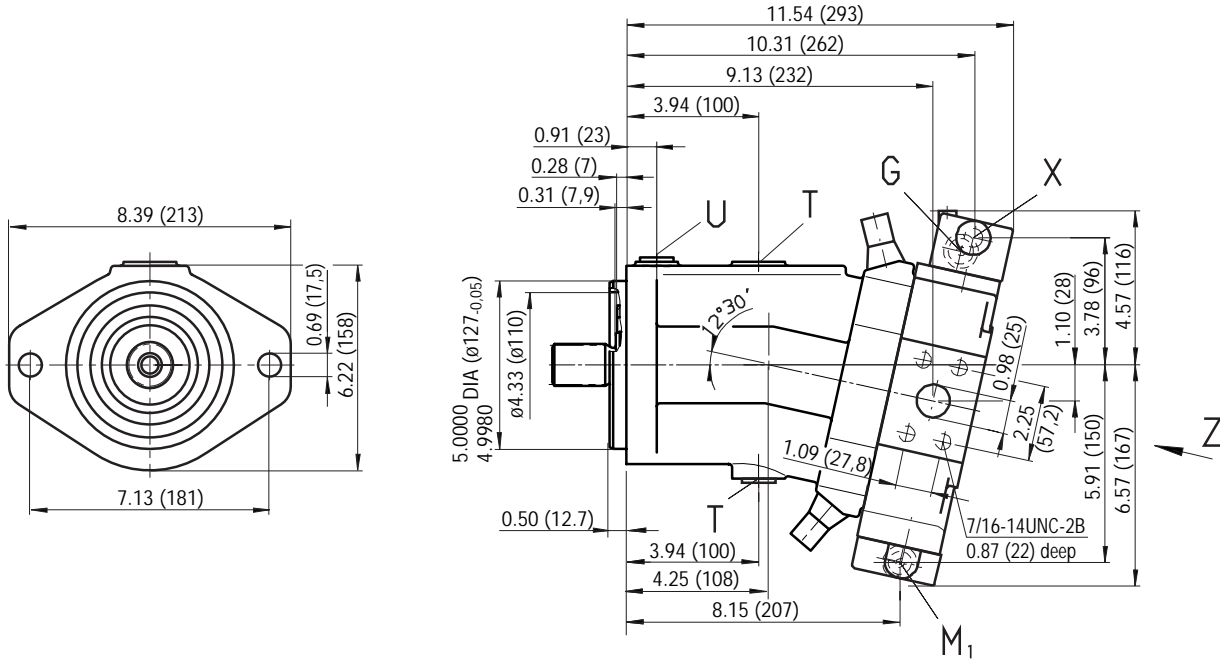

Service line ports A/B at rear end (51)
View Z

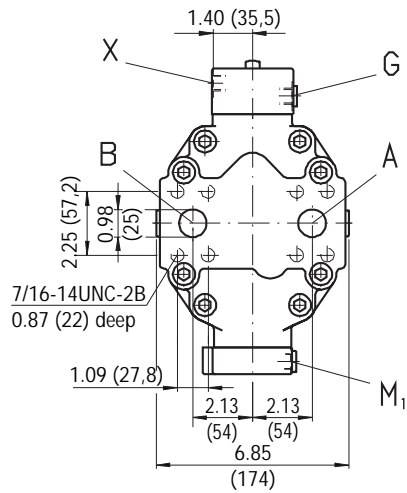

Service line ports A/B on (opposite) sides (52)
View Z

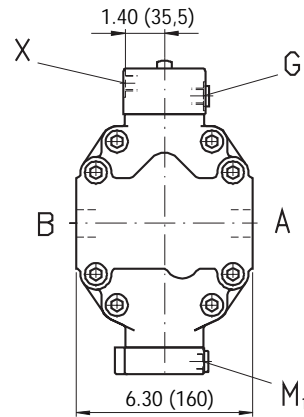

Shaft end

S

Splined Shaft, SAE 1 1/4"
14 T, 12/24 DP, Tolerance class 5
ANSI B92.1a-1976

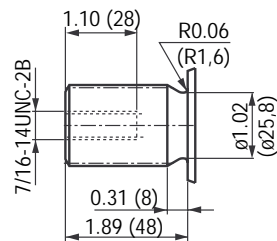

Connections

A,B	Service line ports 6000 psi (420 bar) high pressure series	SAE 1"
G	Port for synchronous control of a number of units and for remote control pressure (plugged)	SAE 6, 9/16-18UNF-2B
X	Pilot pressure port	SAE 6, 9/16-18UNF-2B
T	Case drain ports	SAE 12, 1 1/16-12UN-2B
U	Flushing port (plugged)	SAE 10, 7/8-14UNF-2B
M ₁	Test port for control pressure (plugged)	SAE 6, 9/16-18UNF-2B

Unit Dimensions, Size 107 (SAE Version)

Hydraulic control, pilot pressure related HD1, HD2

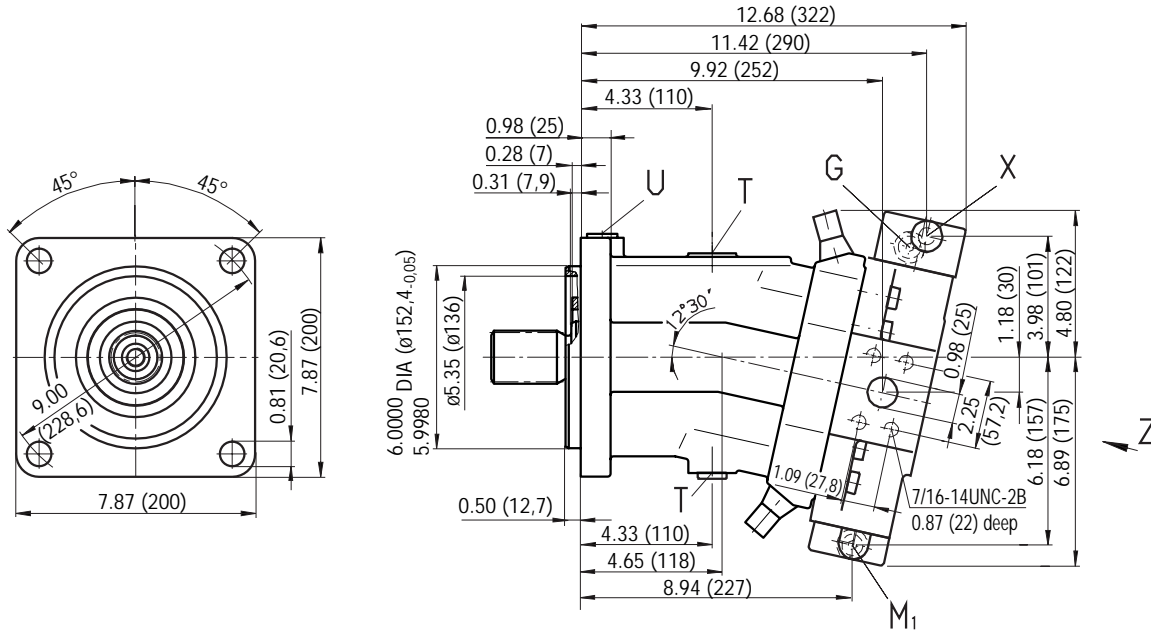

Service line ports A/B at rear end (51)
View Z

Service line ports A/B on (opposite) sides (52)
View Z

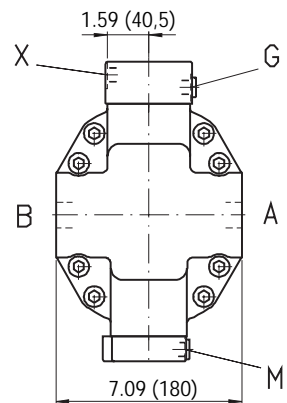
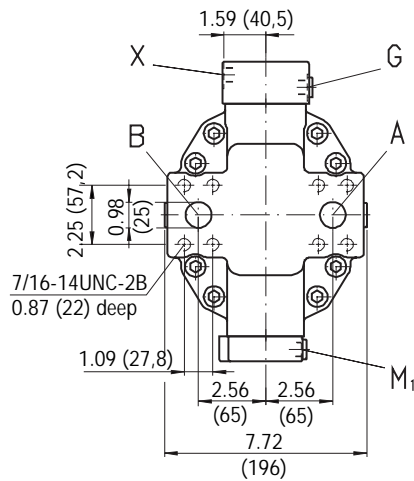

Shaft end S

Splined shaft, SAE 1 3/4"
13 T, 8/16 DP, Tolerance class 5
ANSI B92.1a-1976

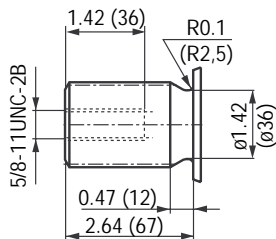

Connections

A,B	Service line ports	SAE 1"
	6000 psi (420 bar) high pressure series	
G	Port for synchronous control of a number of units and for remote control pressure (plugged)	SAE 6, 9/16-18UNF-2B
X	Pilot pressure port	SAE 6, 9/16-18UNF-2B
T	Case drain ports	SAE 12, 1 1/16-12UN-2B
U	Flushing port (plugged)	SAE 10, 7/8-14UNF-2B
M ₁	Test port for control pressure (plugged)	SAE 6, 9/16-18UNF-2B

Unit Dimensions, Size 140 (ISO Version)

Hydraulic control, pilot pressure related HD1, HD2
Hydraulic two-position control HZ1

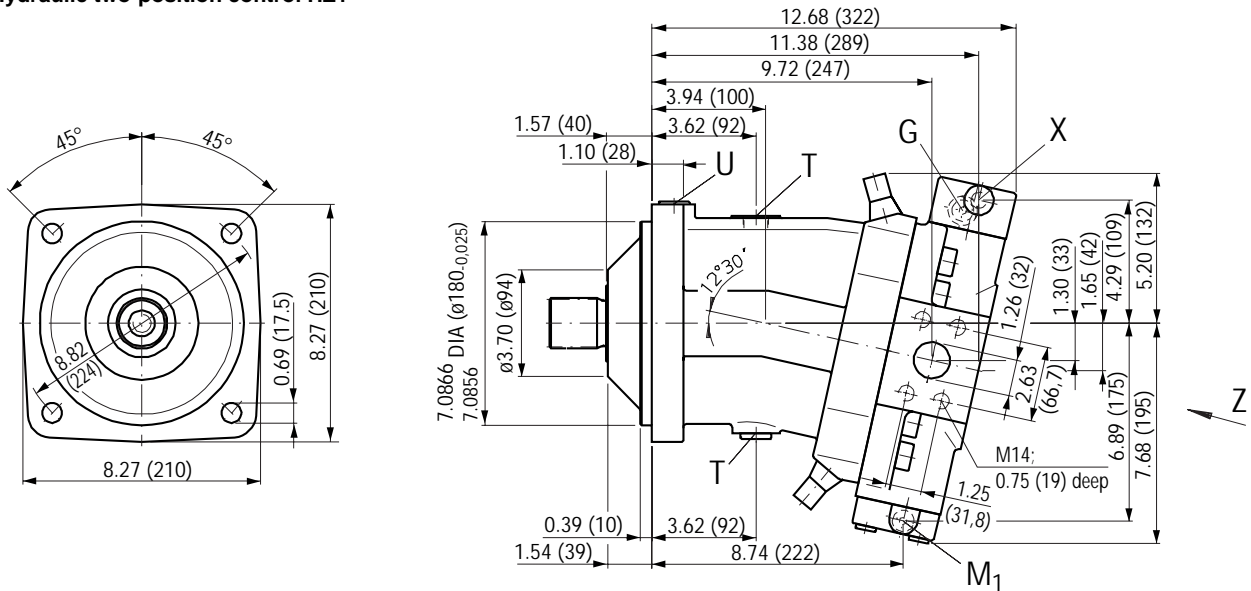

Service line ports A/B at rear end (01)
View Z

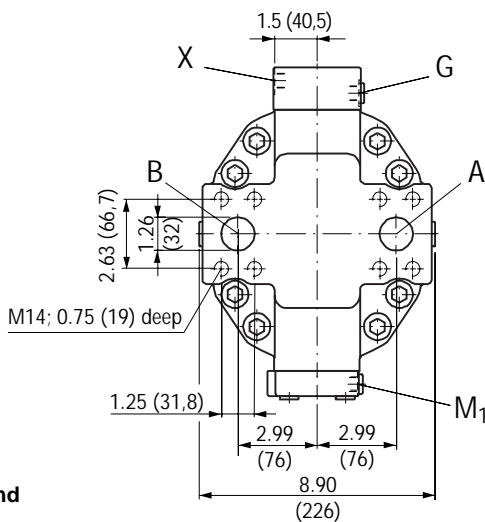

Service line ports A/B on (opposite) sides (02)
View Z

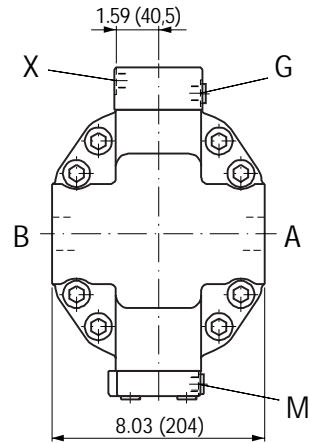

Shaft end

Z

Splined shaft, DIN 5480
W 45x2x30x21x9g

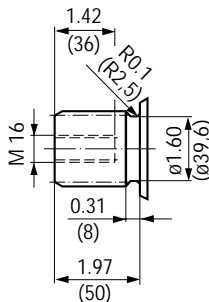

Connections

A,B	Service line ports 6000 psi (420 bar) high pressure series	SAE 1 1/4"
G	Port for synchronous control of a number of units and for remote control pressure (plugged)	M14x1,5
X	Pilot pressure port	M14x1,5
T	Case drain ports	M26x1,5
U	Flushing port (plugged)	M22x1,5
M ₁	Test port for control pressure (plugged)	M14x1,5

Unit Dimensions, Size 160 (SAE Version)

Hydraulic control, pilot pressure related HD1, HD2
Hydraulic two-position control HZ1

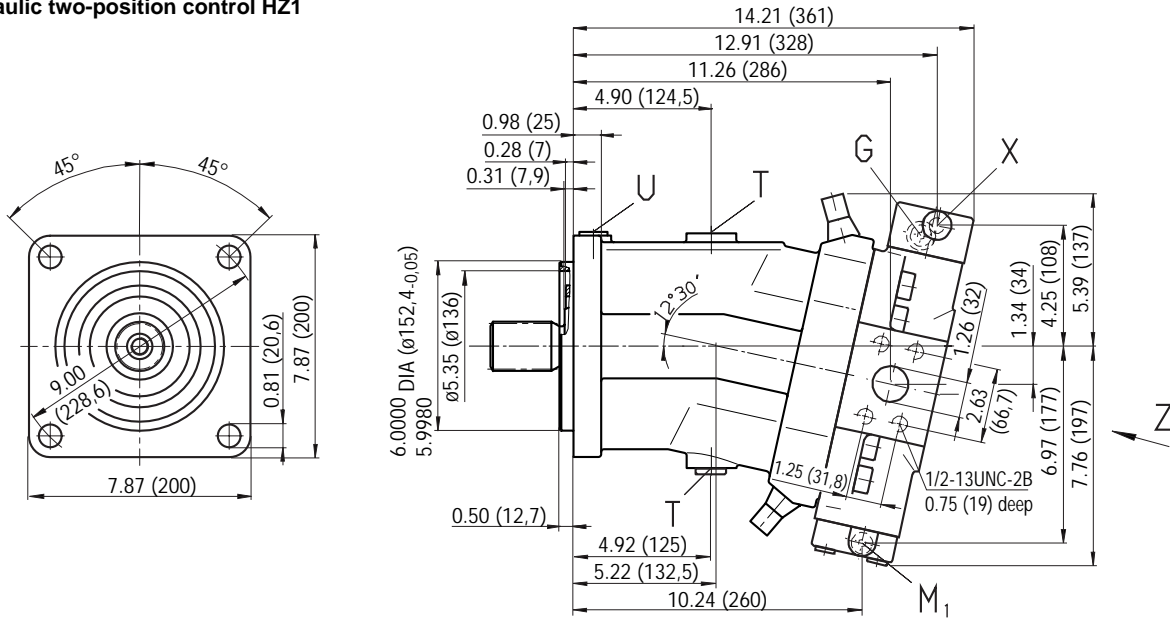

Service line ports A/B at rear end (51)
View Z

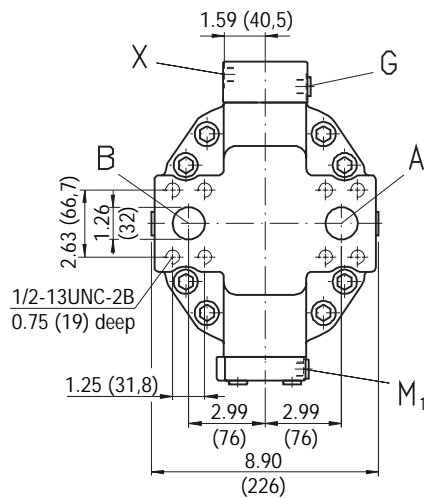

Service line ports A/B on (opposite) sides (52)
View Z

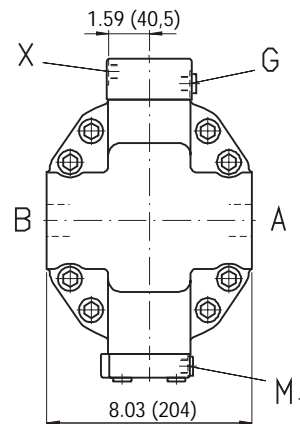

Shaft end

S
Splined shaft, SAE 1 3/4"
13 T, 8/16 DP, Tolerance class 5
ANSI B92.1a-1976

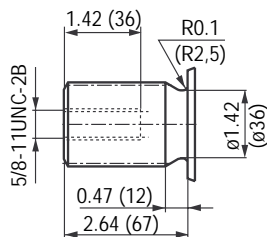

Connections

A,B	Service line ports	SAE 1 1/4"
	6000 psi (420 bar) high pressure series	
G	Port for synchronous control of a number of units and for remote control pressure (plugged)	SAE 6, 9/16-18UNF-2B
X	Pilot pressure port	SAE 6, 9/16-18UNF-2B
T	Case drain ports	SAE 12, 1 1/16-12UN-2B
U	Flushing port (plugged)	SAE 10, 7/8-14UNF-2B
M ₁	Test port for control pressure (plugged)	SAE 6, 9/16-18UNF-2B

Unit Dimensions, Size 200 (SAE Version)

Hydraulic control, pilot pressure related HD1, HD2
Hydraulic two-position control HZ1

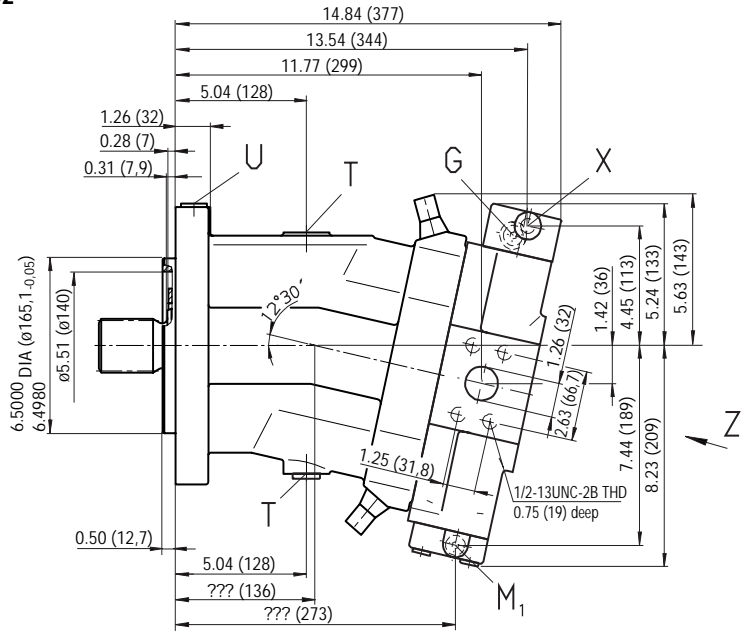
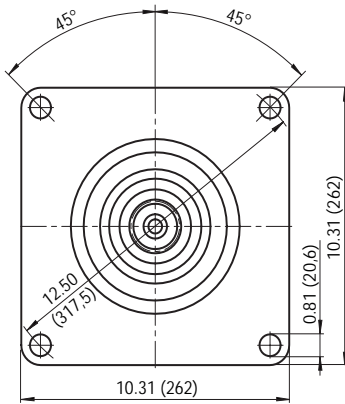

Service line ports A/B at rear end (51)
View Z

Service line ports A/B on (opposite) sides (52)
View Z

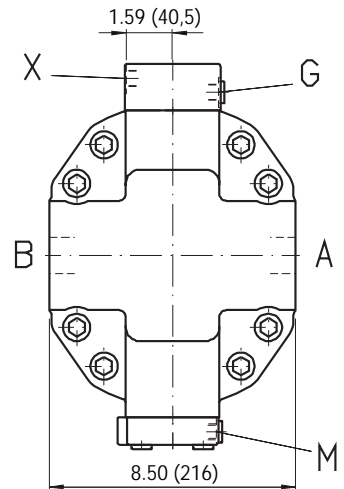
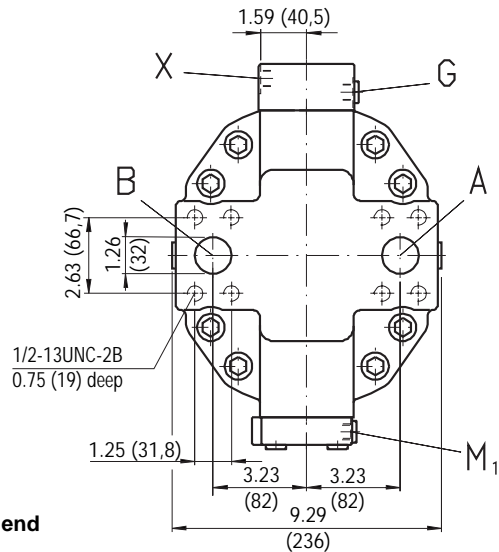

Shaft end S

Splined shaft, SAE 2"
15 T, 8/16 DP, Tolerance class 5
ANSI B92.1a-1976

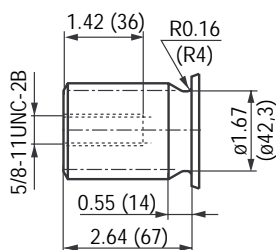

Connections

A,B	Service line ports	SAE 1 1/4"
	6000 psi (420 bar) high pressure series	
G	Port for synchronous control of a number of units and for remote control pressure (plugged)	SAE 6, 9/16-18UNF-2B
X	Pilot pressure port	SAE 6, 9/16-18UNF-2B
T	Case drain ports	SAE 12, 1 1/16-12UN-2B
U	Flushing port (plugged)	SAE 10, 7/8-14UNF-2B
M ₁	Test port for control pressure (plugged)	SAE 6, 9/16-18UNF-2B

Unit Dimensions, Size 250 (SAE Version)

Hydraulic control, pilot pressure related HD1, HD2
Hydraulic two-position control HZ

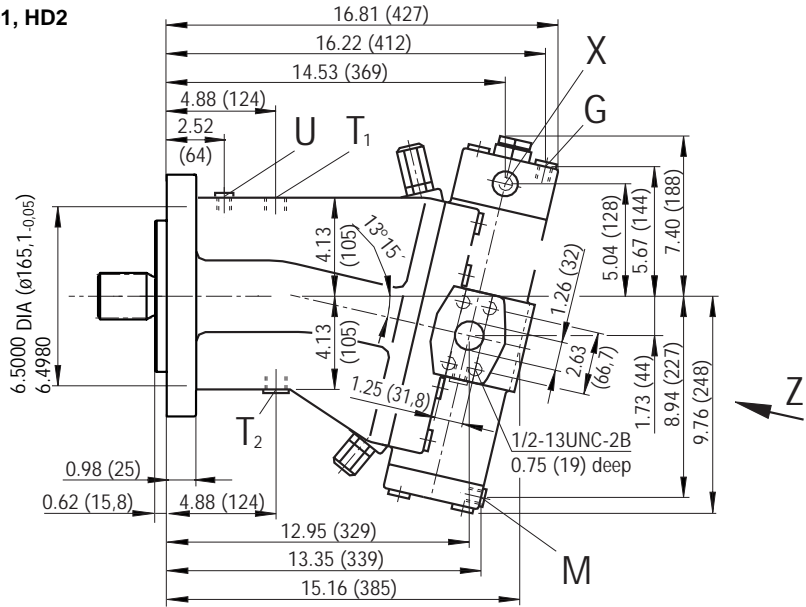
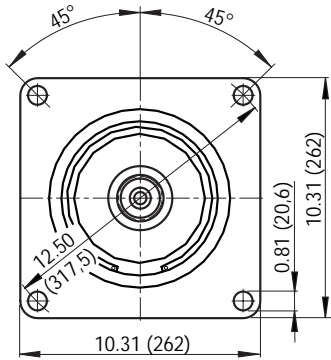

Service line ports A/B at rear end (51)

View Z

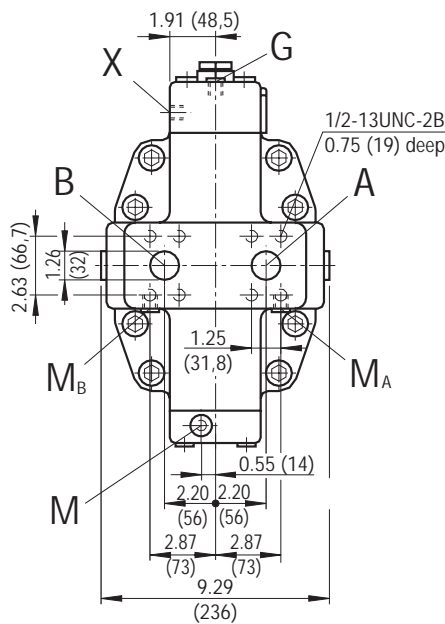

Service line ports A/B on (opposite) sides (52)

View Z

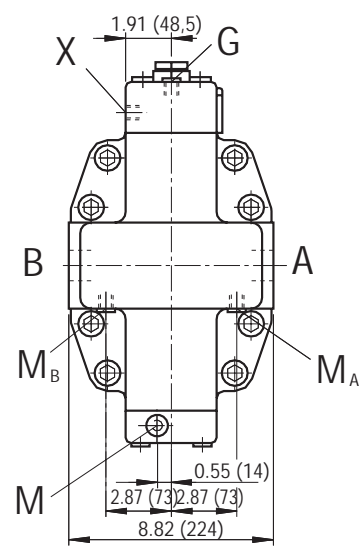

Shaft end

S

Splined shaft, SAE 2"
15 T, 8/16 DP, Tolerance class 5
ANSI B92.1a-1976

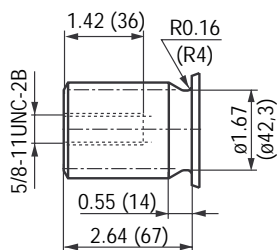

Connections

A,B	Service line ports 6000 psi (420 bar) high pressure series	SAE 1 1/4"
G	Port for synchronous control of a number of units and for remote control pressure (plugged)	SAE 6, 9/16-18UNF-2B
X	Pilot pressure port	SAE 6, 9/16-18UNF-2B
T ₁ , T ₂	Case drain ports	SAE 10, 7/8-14UNF-2B
U	Flushing port (plugged)	SAE 6, 9/16-18UNF-2B
M _A , M _B	Test ports	SAE 6, 9/16-18UNF-2B
M	Test port for control pressure (plugged)	SAE 6, 9/16-18UNF-2B

Unit Dimensions, Size 355 (ISO Version)

Hydraulic control, pilot pressure related HD1, HD2
Hydraulic two-position control HZ

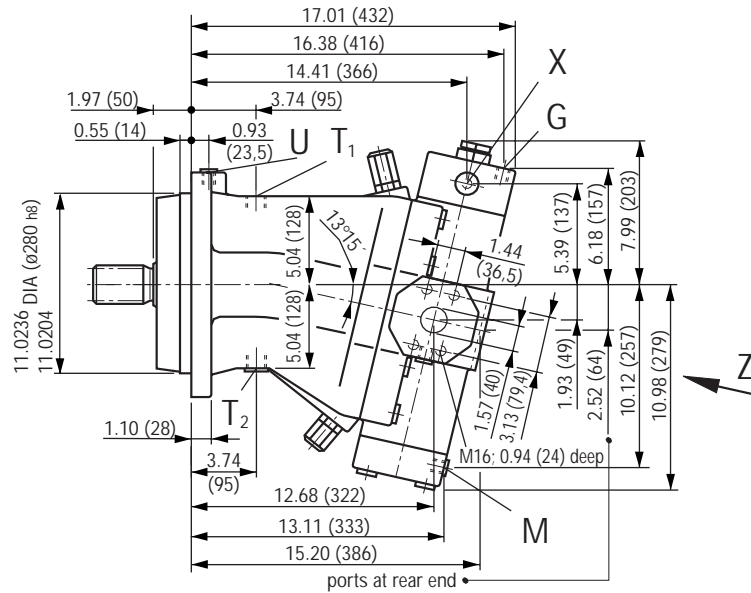
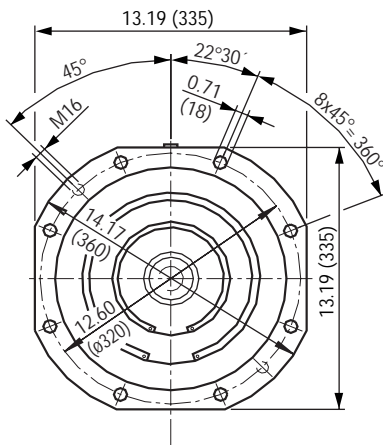

Service line ports A/B at rear end (01)

Service line ports A/B on (opposite) sides (02)

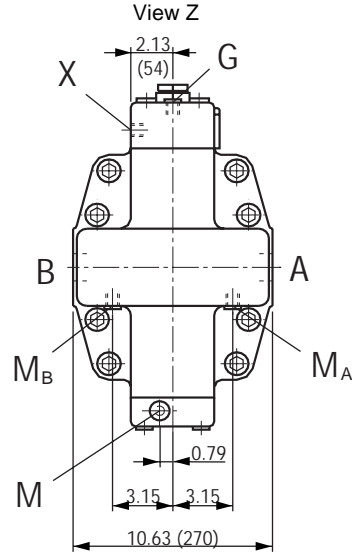
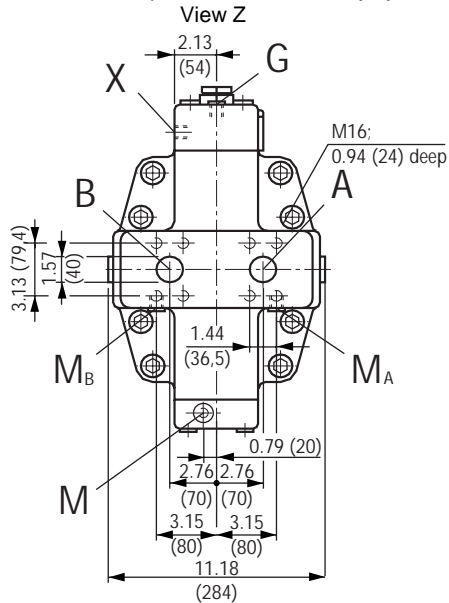

Shaft ends

Z
Splined shaft, DIN 5480
W 60x2x30x28x9g

P
Parallel shaft, DIN 6885
with key AS 18x11x100 (mm)

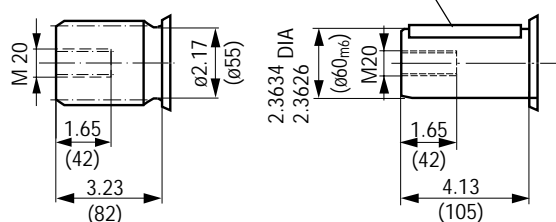

Connections

A, B	Service line ports 6000 psi (420 bar) high pressure series	SAE 1 1/2"
G	Port for synchronous control of a number of units and for remote control pressure (plugged)	M14x1,5
X	Pilot pressure port	M14x1,5
T ₁ , T ₂	Case drain ports	M33x2
U	Flushing port (plugged)	M14x1,5
M _A , M _B	Test ports	M14x1,5
M	Test port for control pressure (plugged)	M14x1,5

Unit Dimensions, Size 500 (ISO Version)

Hydraulic control, pilot pressure related HD1, HD2
Hydraulic two-position control HZ

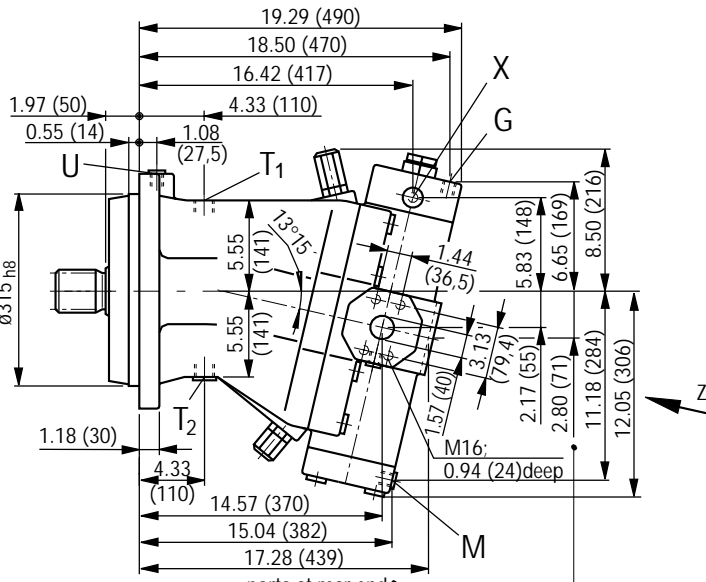
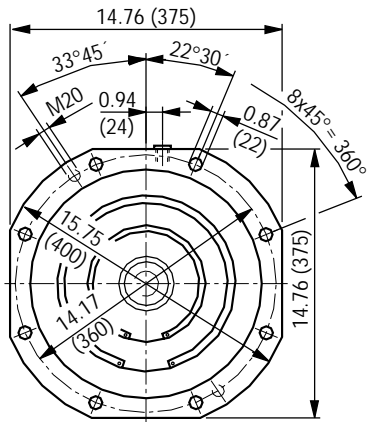

Service line ports A/B at rear end (01)

Service line ports A/B on (opposite) sides (02)

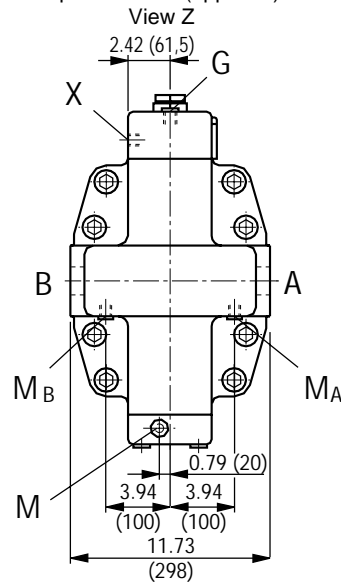
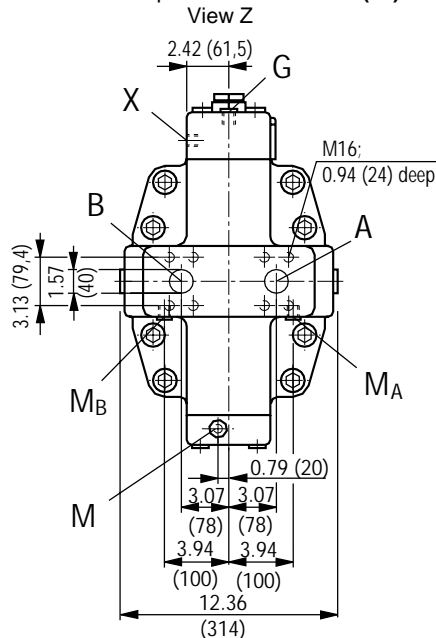

Shaft ends

Z
Splined shaft, DIN 5480
W 70x3x30x22x9g

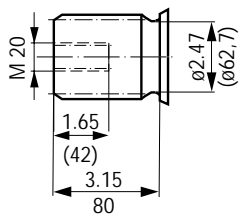

P
Parallel shaft, DIN 6885
with key AS 20x12x100 (mm)

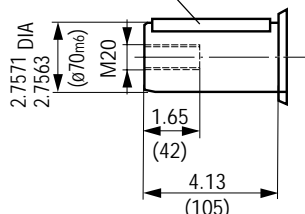

Connections

A,B	Service line ports	SAE 1 1/2"
	6000 psi (420 bar) high pressure series	
G	Port for synchronous control of a number of units and for remote control pressure (plugged)	M18x1,5
X	Pilot pressure port	M14x1,5
T ₁ , T ₂	Case drain ports	M33x2
U	Flushing port (plugged)	M18x1,5
M _A , M _B	Test ports	M14x1,5
M	Test port for control pressure (plugged)	M14x1,5

Unit Dimensions, Size 1000 (ISO Version)

Hydraulic control, pilot pressure related HD1, HD2
Hydraulic two-position control HZ

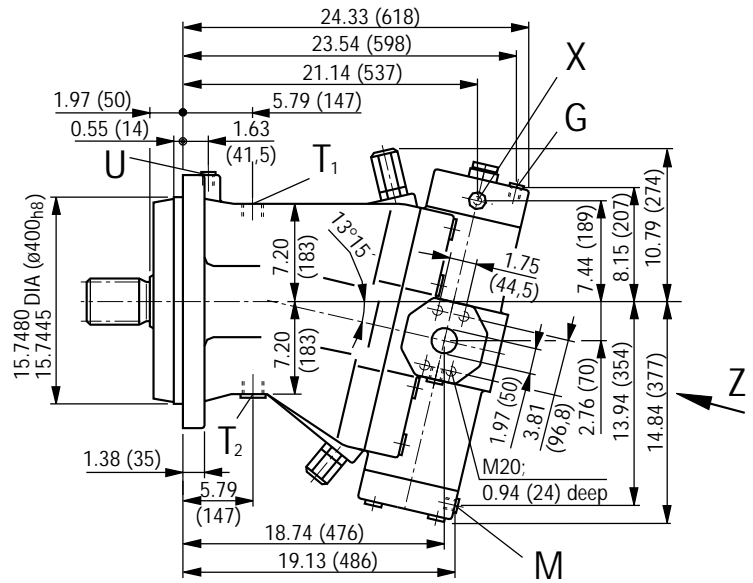
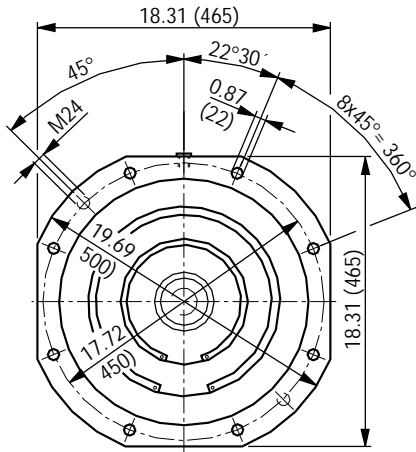

Sorts A/B on (opposite) sides (02)
View Z

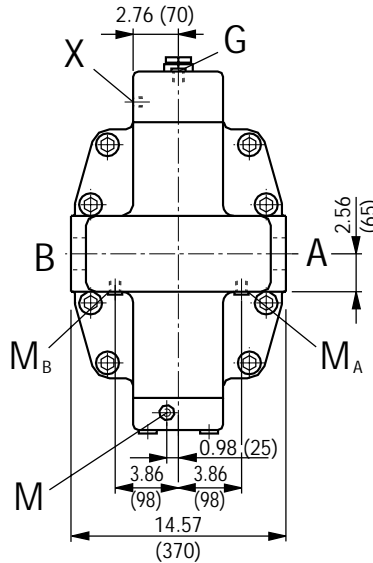

Shaft ends

Z
Splined shaft, DIN 5480
W 90x3x30x28x9g

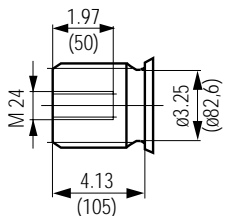

P
Parallel shaft, DIN 6885
with key AS 25x14x125 (mm)

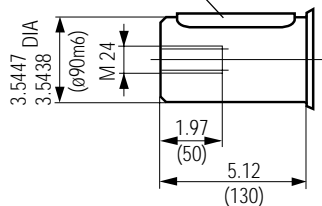

Connections

A,B	Service line ports	SAE 2"
	6000 psi (420 bar) high pressure series	
G	Port for synchronous control of a number of units and for remote control pressure (plugged)	M18x1,5
X	Pilot pressure port	M14x1,5
T ₁ , T ₂	Case drain ports	M33x2
U	Flushing port (plugged)	M18x1,5
M _A , M _B	Test ports	M14x1,5
M	Test port for control pressure (plugged)	M14x1,5

Swivel Angle Indicator

Optical swivel angle indicator (V)

The swivel position is indicated by a pin on the side of the housing. Depending on the position of the control lens the pin is pushed out. If it is **flush with the housing** the motor is at **zero**.

At max. swivel $V_{g\ max}$ the length of the pin is 0.31 inches (8 mm). (Display is still possible if the protective cap is removed)

Electronical swivel angle indicator (E)

The motor position is fed back here by means of an inductive positional transducer. It converts the displacement of the variable unit into an electrical signal. The swivel position may be further processed by means of this signal, eg. it may be fed to an amplifier card.

Inductive positional transducer type IW9-03-01

Circuit diagram:

Hydraulic control, pilot pressure related HD, with optical swivel angle indicator V

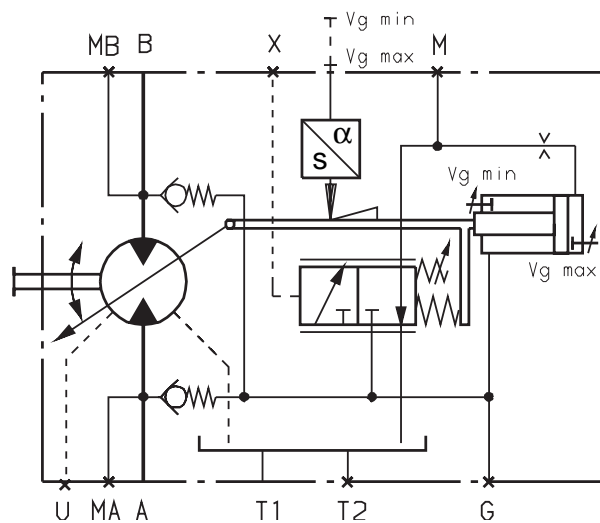

Unit dimensions

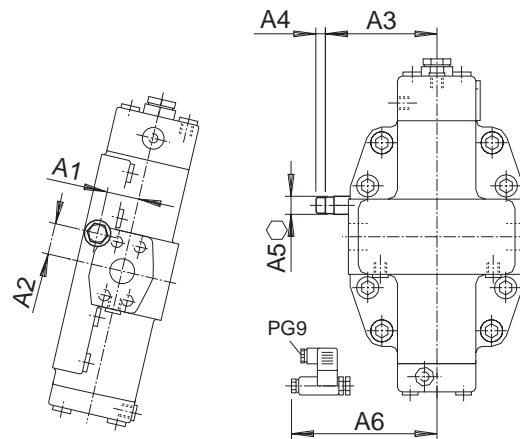

Size	A1	A2	A3	A4 ^{*)}	A5 [○]	A6
250	1.63 (41.3)	1.57 (40)	5.37 (136.5)	0.43 (11)	0.75 (19)	7.17 (182)
355	1.83 (46.5)	1.85 (47)	6.28 (159.5)	0.43 (11)	0.75 (19)	8.07 (205)
500	2.00 (50.8)	1.85 (47)	6.79 (172.5)	0.43 (11)	0.75 (19)	8.58 (218)
1000	2.05 (52)	2.05 (52)	8.21 (208.5)	0.43 (11)	0.75 (19)	

^{*)} Space required to remove protective cap

Unit Dimensions - motion control valve

Port plate with pressure relief valves, for mounting a motion control valve (37, 38), sizes 55...160

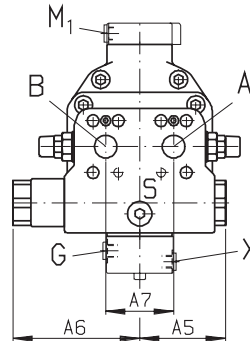
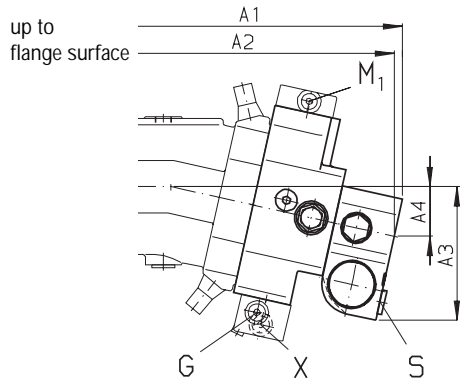

Connections

- A, B Service line ports
6000 psi (420 bar) high pressure series
- S Boosting (plugged)

suitable for mounting:

- 1 Rexroth motion control valve (see RE 64317)
MHB16RNP...18E (size 55, port plate 38)
MHB20RNP...11 (size 55, port plate 38)
MHB20RNP...18 (size 80, port plate 38)
MHB20RNP...18E (size 107, port plate 37)
MHB25RNP...18 (size 107, size 160, port plate 38)
- 1 Rexroth motion control valve (see RE 64316)
MHB30 (size 250, port plate 08)

The motion control valve is not included in the type references, please order separately!
(Exception: size 250, port plate 088, with mounted motion control valve!)

We recommend total supply through Rexroth!

Sizes 55...160

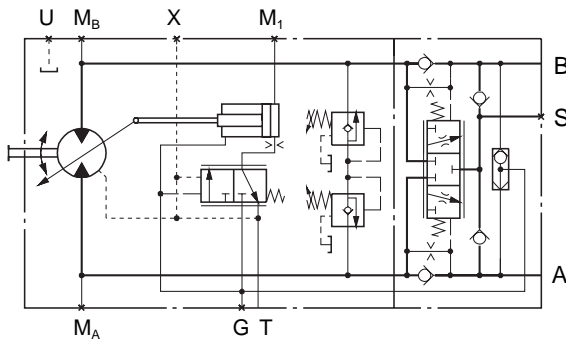

Size 250

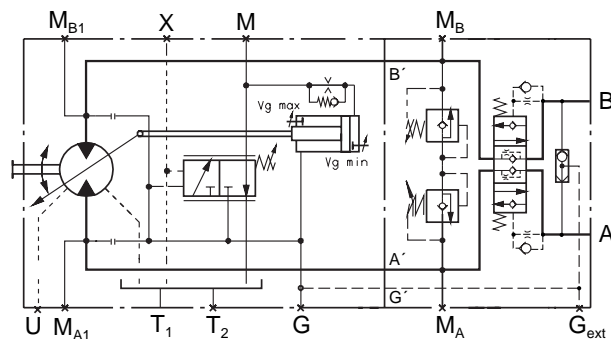

Size	port plate	A1	A2	A3	A4	A5	A6	A7	ports A, B	boosting S
55	38	12.24	11.89	5.63	1.97	3.78	5.47	2.95	SAE 3/4"	M22x1,5
		(311)	(302)	(143)	(50)	(96)	(139)	(75)	SAE 3/4"	M22x1,5
80	38	13.39	13.03	5.83	2.16	3.78	5.47	2.95	SAE 1"	M22x1,5
		(340)	(331)	(148)	(55)	(96)	(139)	(75)	SAE 1"	M22x1,5
107	37	14.25	13.90	5.98	2.32	3.78	5.47	3.31	SAE 1"	M22x1,5
		(362)	(353)	(152)	(59)	(96)	(139)	(84)	SAE 1"	M22x1,5
107	38	14.96	14.57	6.50	2.48	4.74	6.52	3.31	SAE 1 1/4"	M27x2
		(380)	(370)	(165)	(63)	(120.5)	(165.5)	(84)	SAE 1 1/4"	M27x2
160	38	16.42	16.02	6.65	2.68	4.74	6.52	3.31	SAE 1 1/4"	M27x2
		(417)	(407)	(169)	(68)	(120.5)	(165.5)	(84)	SAE 1 1/4"	M27x2
250	08	17.80	14.17	8.93	-	9.49	9.49	3.82	SAE 1 1/4"	-
		(452)	(360)	(227)	-	(241)	(241)	(97)	SAE 1 1/4"	-

Unit Dimensions - flushing and boost pressure valve (7)

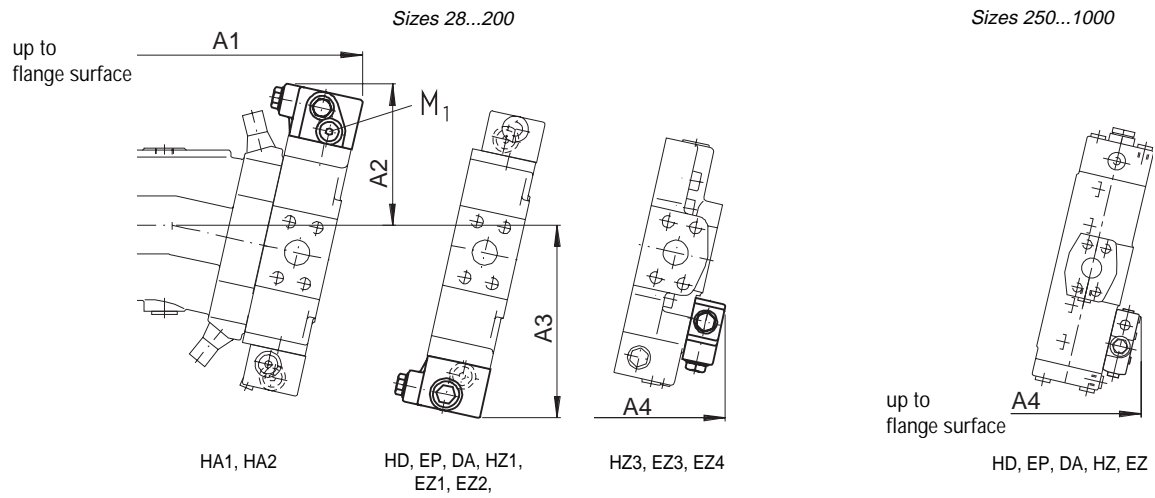

Size	A1	A2	A3	A4
A6VM 28	8.43	4.92	6.34	—
	(214)	(125)	(161)	—
140	12.64	6.06	8.58	—
	(231)	(154)	(218)	—
AA6VM 55	10.51	5.24	6.93	10.24
	(267)	(133)	(176)	(260)
80	11.69	5.59	7.60	10.94
	(297)	(142)	(193)	(278)
107	12.60	5.67	7.87	11.85
	(320)	(144)	(200)	(301)
160	14.17	6.06	8.66	—
	(360)	(154)	(220)	—
200	14.84	6.30	9.09	—
	(377)	(160)	(231)	—

Size	A4
AA6VM 250	15.63
	(397)
A6VM 355	17.56
	(446)
500	—
1000	—

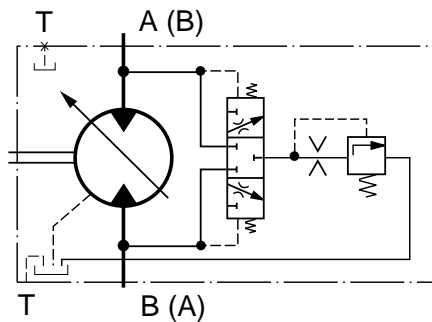

Variable Displacement Motor AA6VM (A6VM)

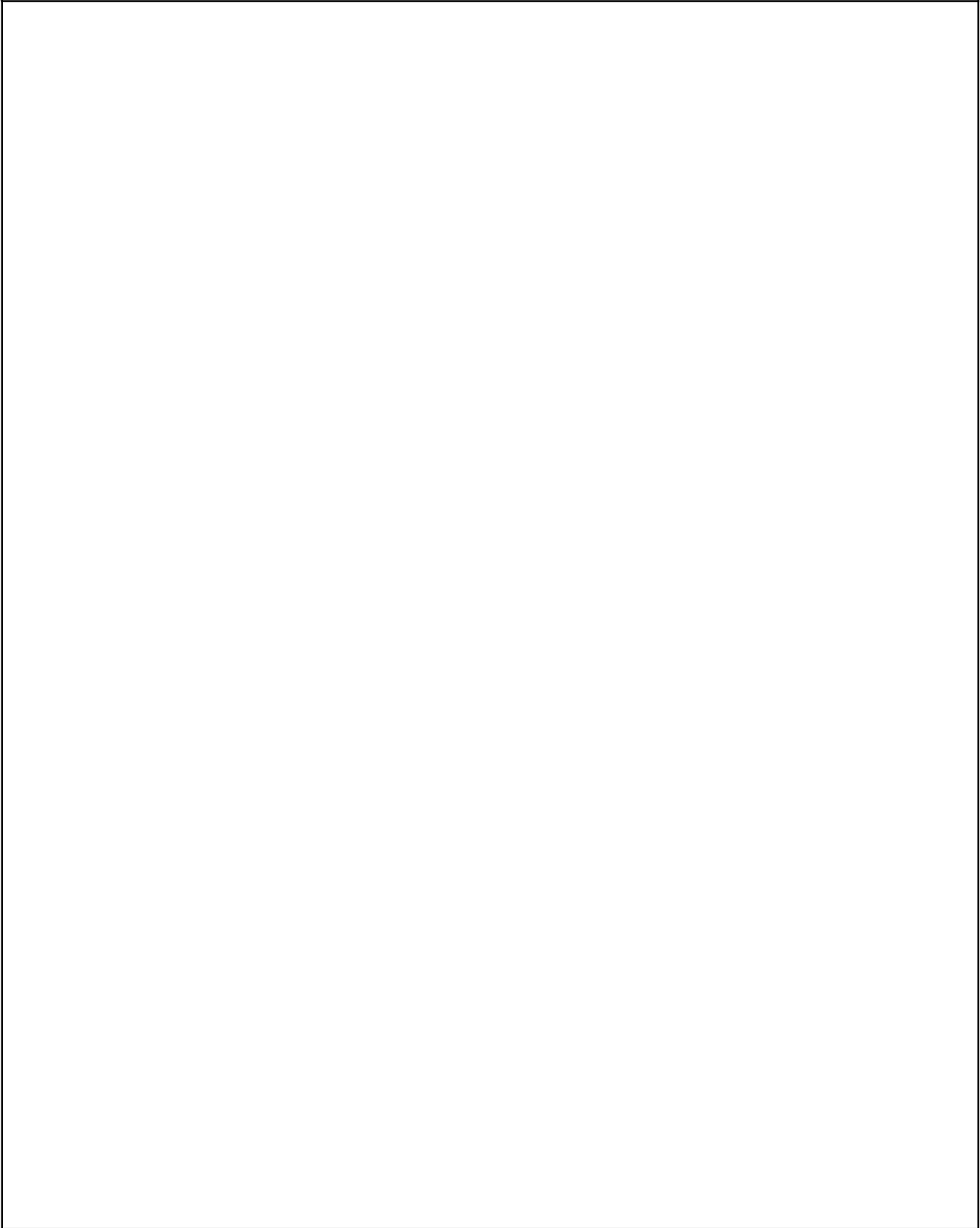

Mannesmann Rexroth Corporation
Rexroth Hydraulics Div., Industrial, 2315 City Line Road, Bethlehem, PA 18017-2131 Tel. (610) 694-8300 Fax: (610) 694-8467
Rexroth Hydraulics Div., Mobile, 1700 Old Mansfield Road, Wooster, OH 44691-0394 Tel. (330) 263-3400 Fax: (330) 263-3333